



ALUMINIUM CRÉATIONS SA  
Rue du Châtelard 18  
CH 1400 Yverdon-les-Bains  
T : +41 (0) 58 206 0 206  
F : +41 (0) 58 206 0 200  
[www.alucreations.ch](http://www.alucreations.ch)

VÉRANDAS

BAIES VITRÉES  
& FENÊTRES

PERGOLAS

STORES

CONSTRUCTIONS  
MÉTALLIQUES



# Architect manual

## NGS





ALUMINIUM CRÉATIONS SA  
Rue du Châtelard 18  
CH 1400 Yverdon-les-Bains  
T : +41 (0) 58 206 0 206  
F : +41 (0) 58 206 0 200  
[www.alucreations.ch](http://www.alucreations.ch)

VÉRANDAS

BAIES VITRÉES  
& FENÊTRES

PERGOLAS

STORES

CONSTRUCTIONS  
MÉTALLIQUES

NG S4

NG S5

NG S6

NG S7

## minimal windows® NG S4

01

- a technical data sheet NG S4

## Technical sections

02

- a outer frame
- b sasch frame "view" & "floor"
- c handle bar- double vent profiles
- d junction profiles
- e locking
- f highline type 3
- g further development (\*)

## Elements

03

- a 1x fix 1R & 2x fix highline
- b SF
- c SS
- d FSSF (2R) (double vent)
- e SSSS (2R) (double vent)
- f SSF (3R)
- g SSS (3R)
- h other possibilities (\*)

## Electronics

04

- a selection criterion table  
LD350 & LD700
- b smart slider - lateral drive
- c smart slider - top drive
- d soft open-close (\*)
- e opening monitoring (\*)
- f closure monitoring (\*)

## Accessories

05

- a rollo insect screen
- b other possibilities (\*)

## Test reports

06

- a (\*)

## Building connections

07

- a wall monolithic
- b other possibilities (\*)

## Impressum

08

- a legal information

(\*) in progress



## System

Facing width	: 26 mm
Installation flush to the floor	: possible
Installation flush to the ceiling	: possible
Max. leaf height	: 6 m
Min. B/H	: 1/3
Max. leaf weight	: 1500 kg
Max. leaf area sliding	: 18 m <sup>2</sup>

Max. leaf area fix	: 18 m <sup>2</sup>
Max. numbers of tracks	: up to 5 tracks
Overall insulation glass thickness	: 34 up to 44 mm
Automated sliding leaf	: yes
Motorisation (*)	: up to 2400 kg
(*) total weight with one motor and combined leaves	
Accessibility	: DIN 18040-1, DIN 18040-2

## Building physics

$U_w$ -Values (dep. on glass type & dimensions)	: $\geq 1,2$ W/(m <sup>2</sup> K) (a)   $\geq 0,9$ W/(m <sup>2</sup> K) (b)
Air permeability	: up to classe 4 → EN 12207 (c)
Resistance to rain penetration	: up to classe 8A → EN 12208 (d)
Resistance to wind loads	: up to classe C5 → EN 12210 (c)
Sound insulation	: up to 46 dB → ISO 717-1 (c)

## Safety

Resistance to burglary	: up to RC 3 → EN 1627 (c) & PAS24
------------------------	------------------------------------

- (a) Theoretical R&D calculation for sliding-fixe 6.0 x 6.0 m with glass  $U_g$  1.0 W/m<sup>2</sup>K
- (b) Theoretical R&D calculation for sliding-fixe 4.0 x 6.0 m with HM-glass  $U_g$  0.6 W/m<sup>2</sup>K
- (c) Target value, waiting for official testing
- (d) Target value for drainage type 1 (target value for drainage type 2 & 3 >8A)

## Mounting directions

Max. allowable bending of outer frame

: During assembly
a : $\pm 0.5$ mm / m
b : $\pm 1$ mm
: During operation
a : $\pm 1$ mm / m
b : + 2 / - 5mm

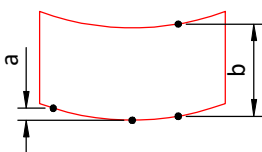



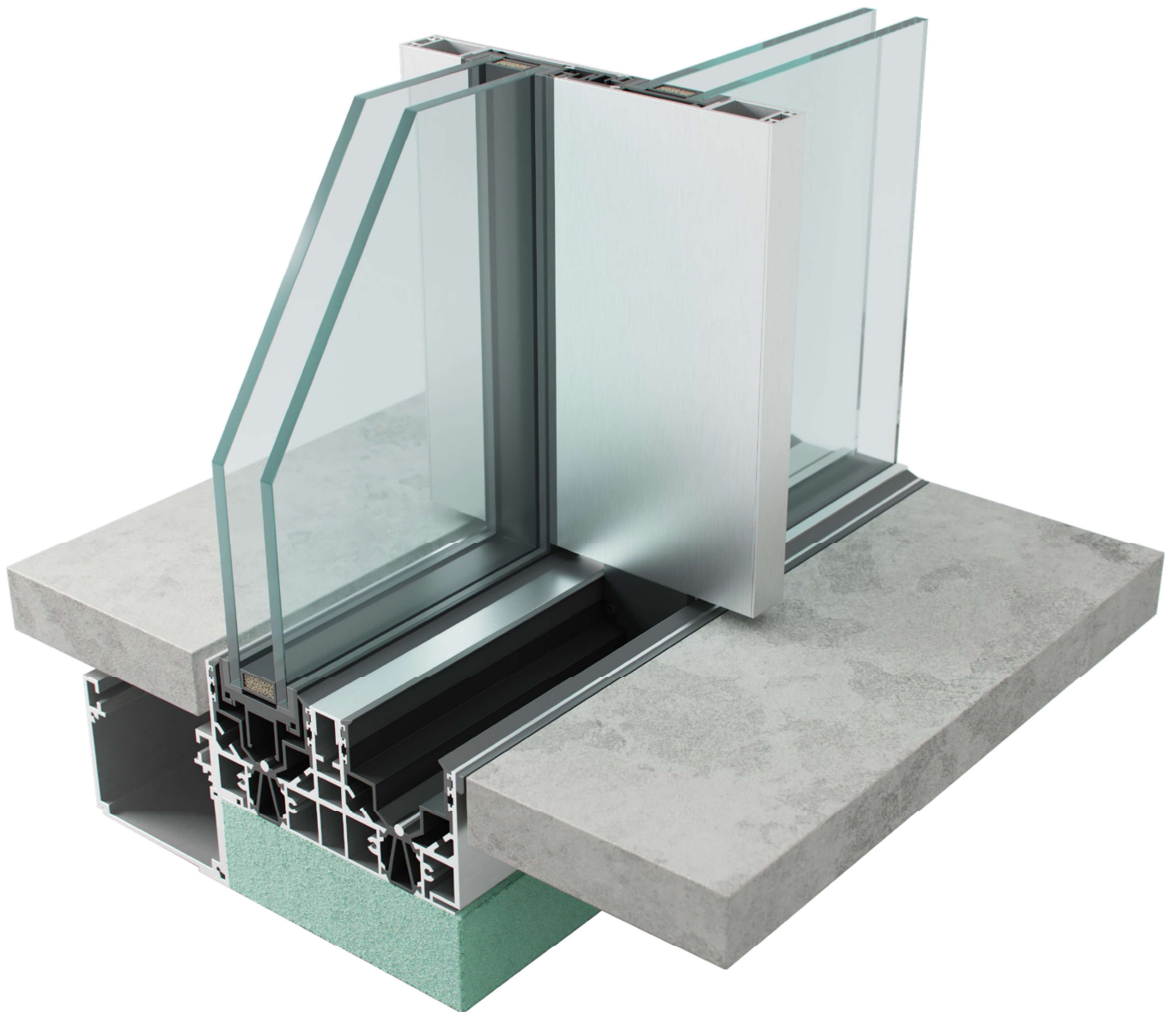

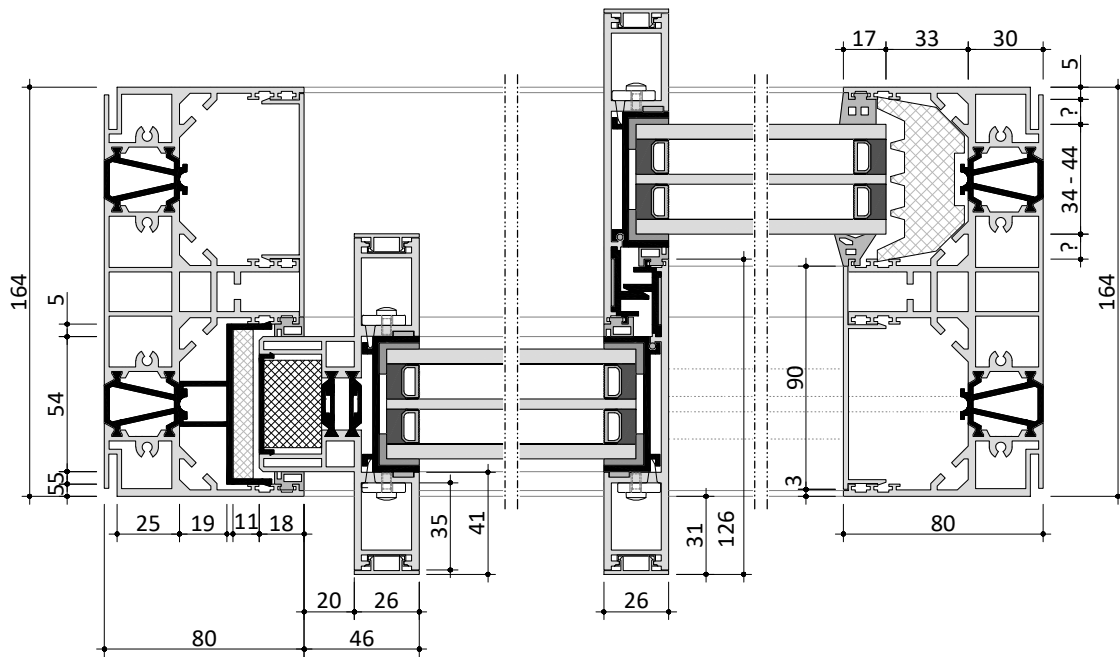
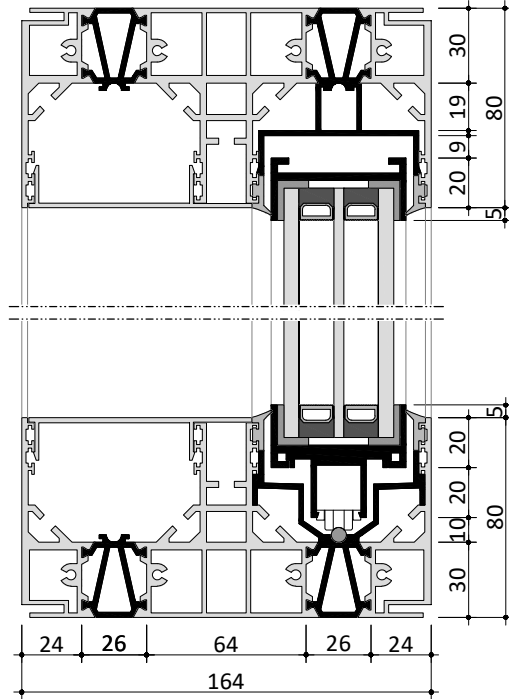
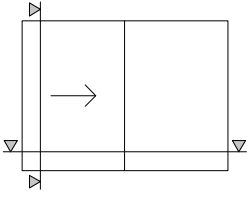



# Technical sections

02-a1

M 1:3 outer frames : view - floor PL - floor CL

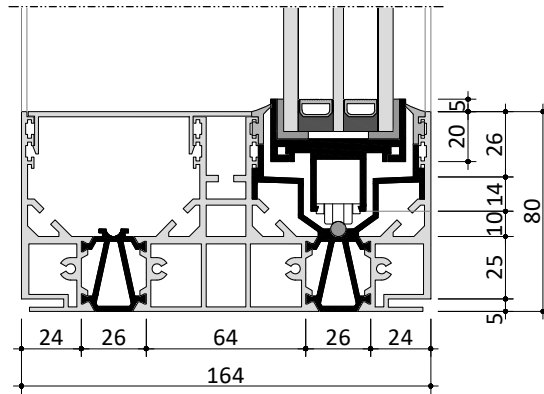
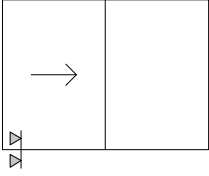

view

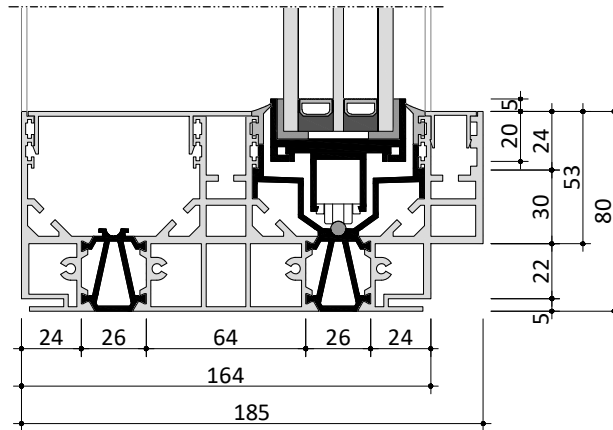

view

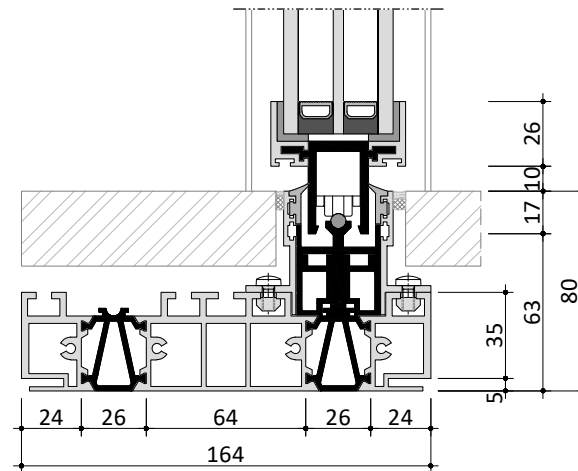

floor PL

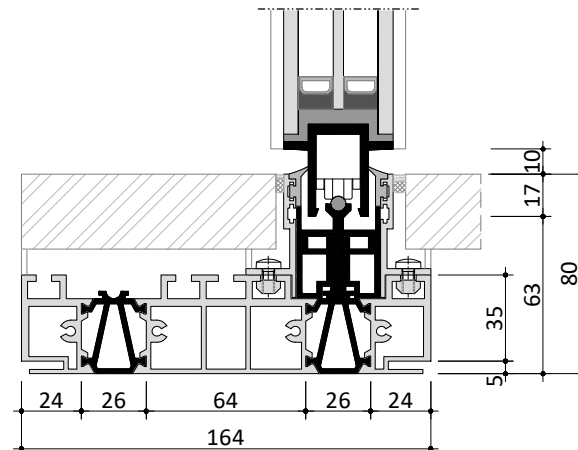

floor CL

M 1:3

outer frames

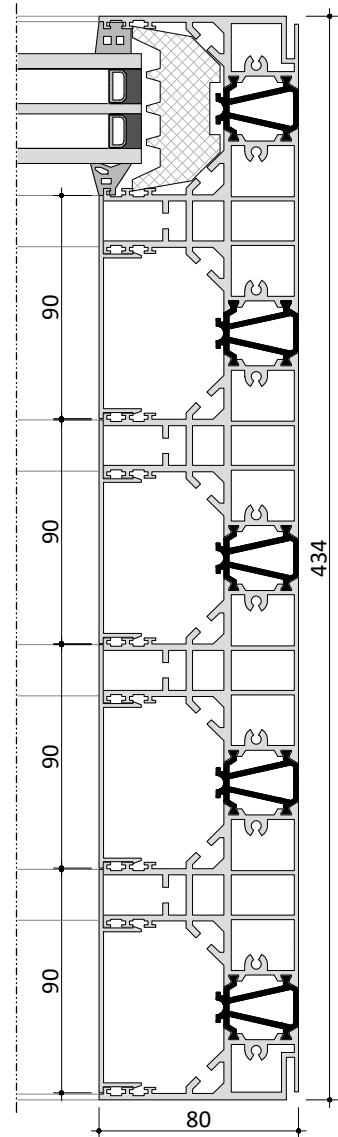
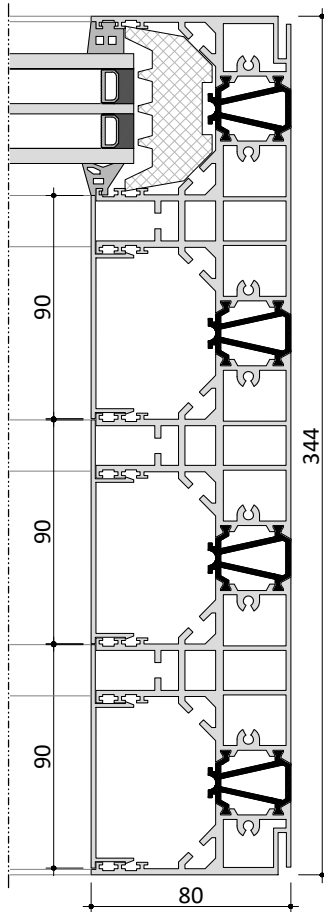
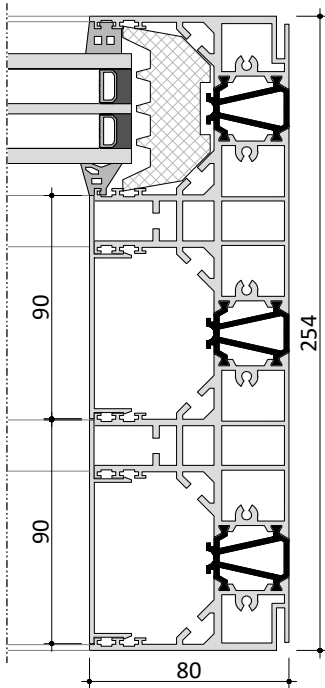
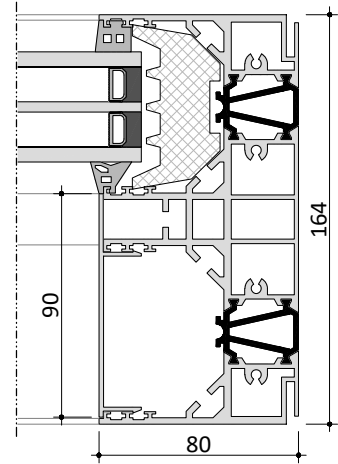
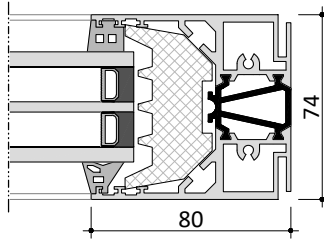
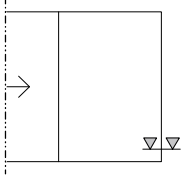



M 1:3

outer frames : Z-schell separator

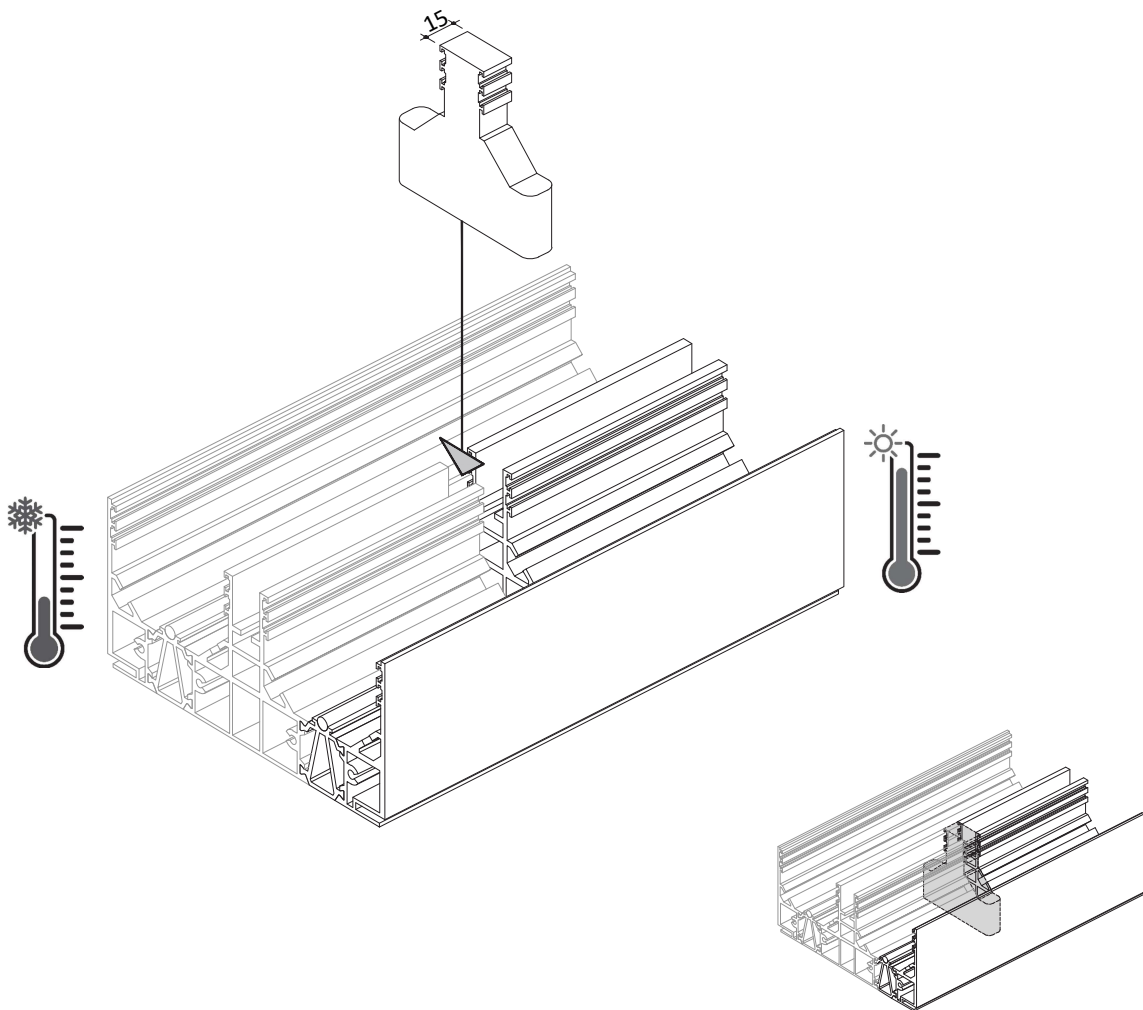
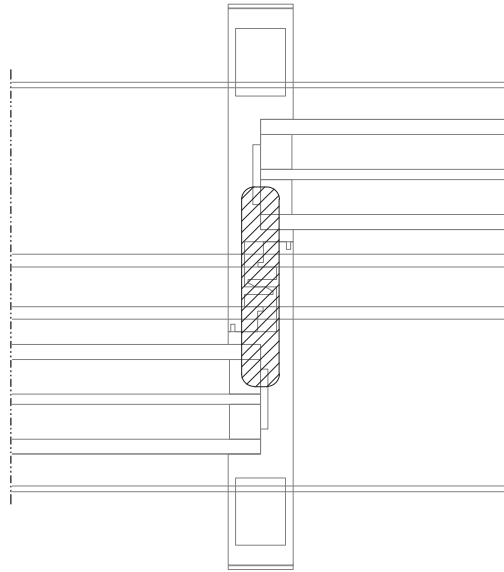
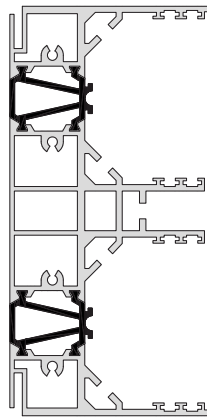
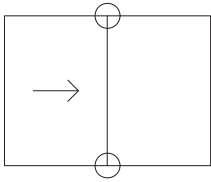

M 1:3

view - sliding

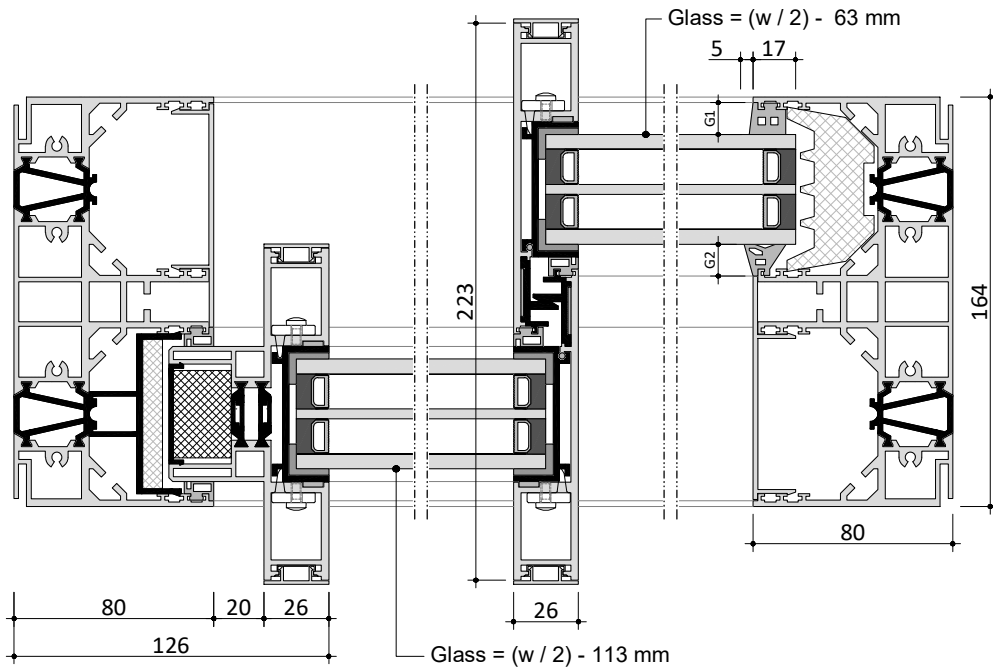
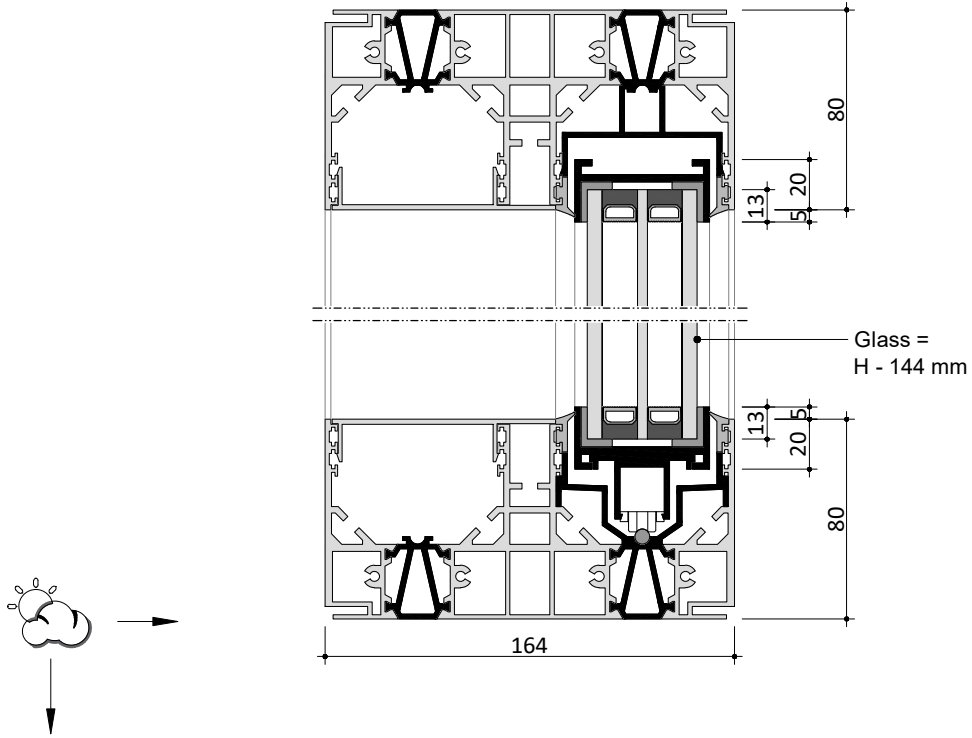
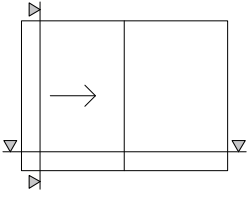



M 1:3

view - fix

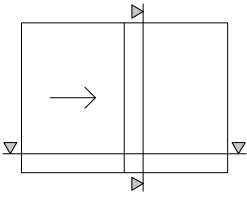

	G1	G2
34mm	15 mm	15 mm
35mm	14 mm	15 mm
36mm	14 mm	15 mm
37mm	13 mm	15 mm
38mm	13 mm	13 mm
39mm	12 mm	13 mm
40mm	12 mm	13 mm
41mm	11 mm	13 mm
42mm	11 mm	11 mm
43mm	10 mm	11 mm
44mm	10 mm	11 mm

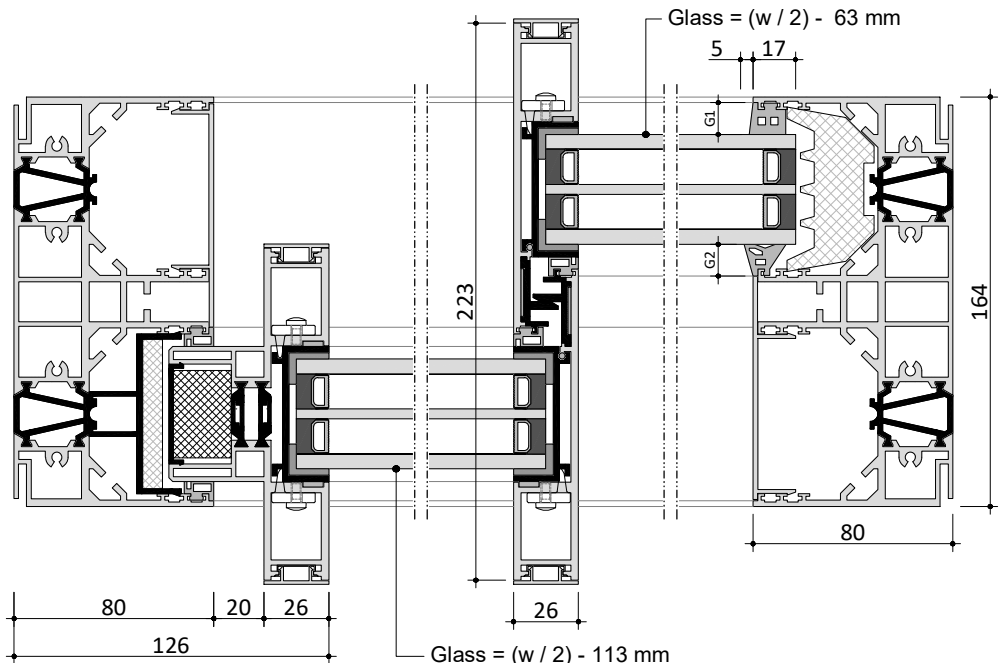
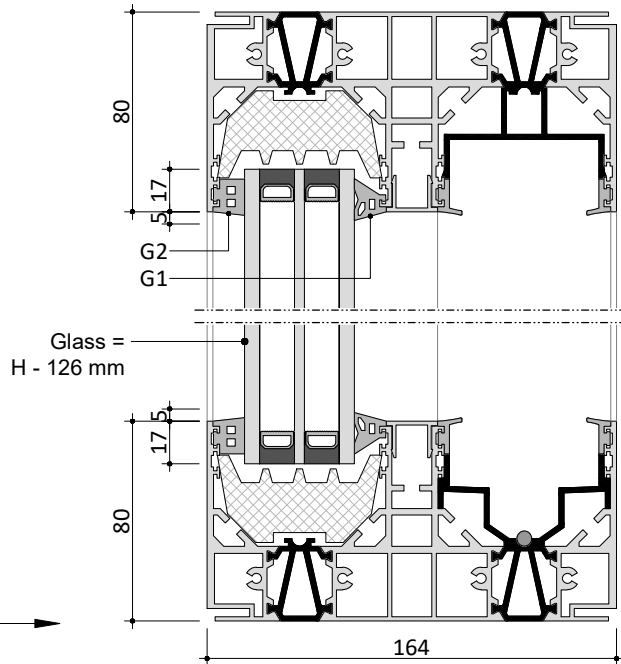

M 1:3

view - sliding with hidden handle

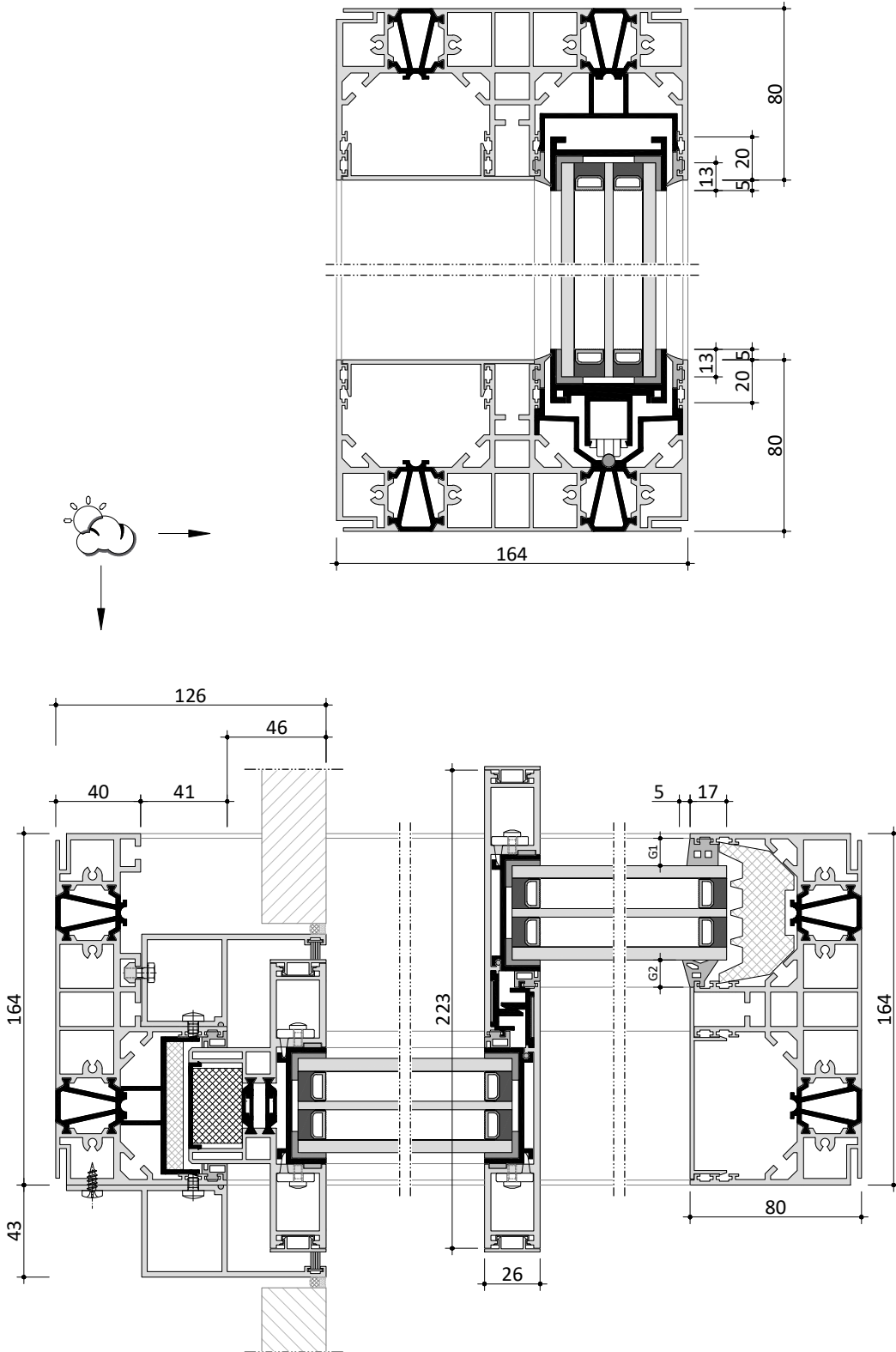
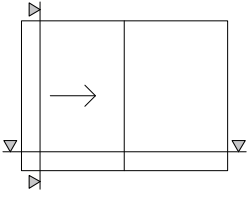

M 1:3

view - fix to hidden handle

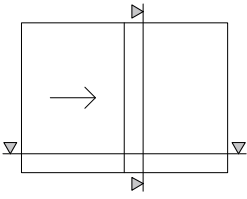

	G1	G2
34mm	15 mm	15 mm
35mm	14 mm	15 mm
36mm	14 mm	15 mm
37mm	13 mm	15 mm
38mm	13 mm	13 mm
39mm	12 mm	13 mm
40mm	12 mm	13 mm
41mm	11 mm	13 mm
42mm	11 mm	11 mm
43mm	10 mm	11 mm
44mm	10 mm	11 mm

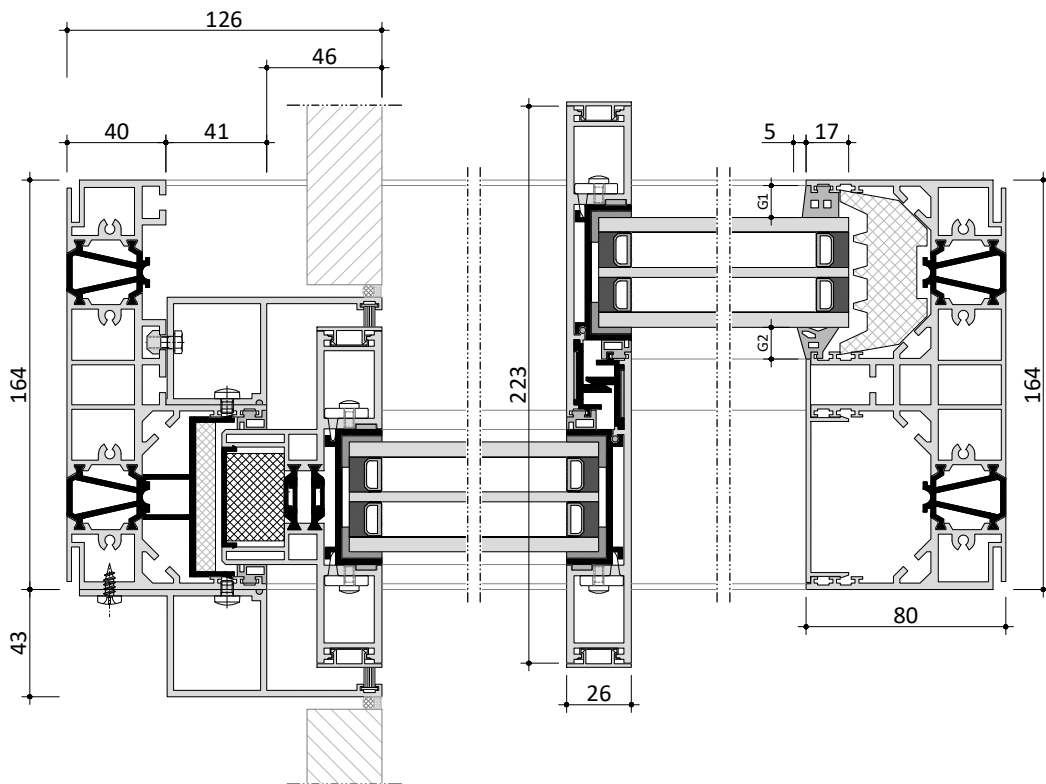
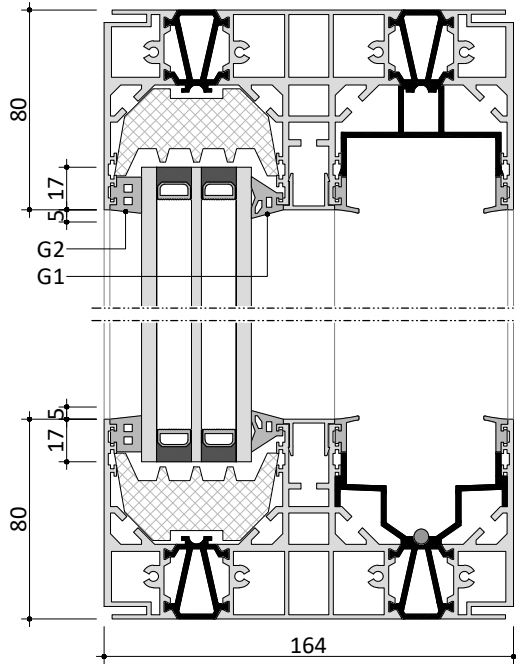

M 1:3

view - sliding - locking groove

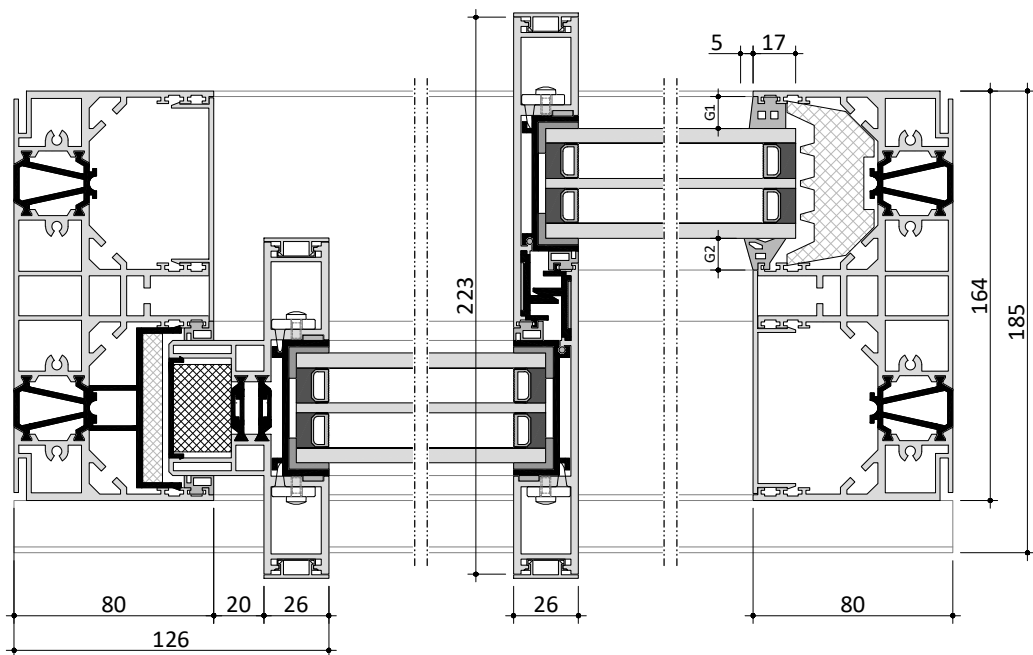
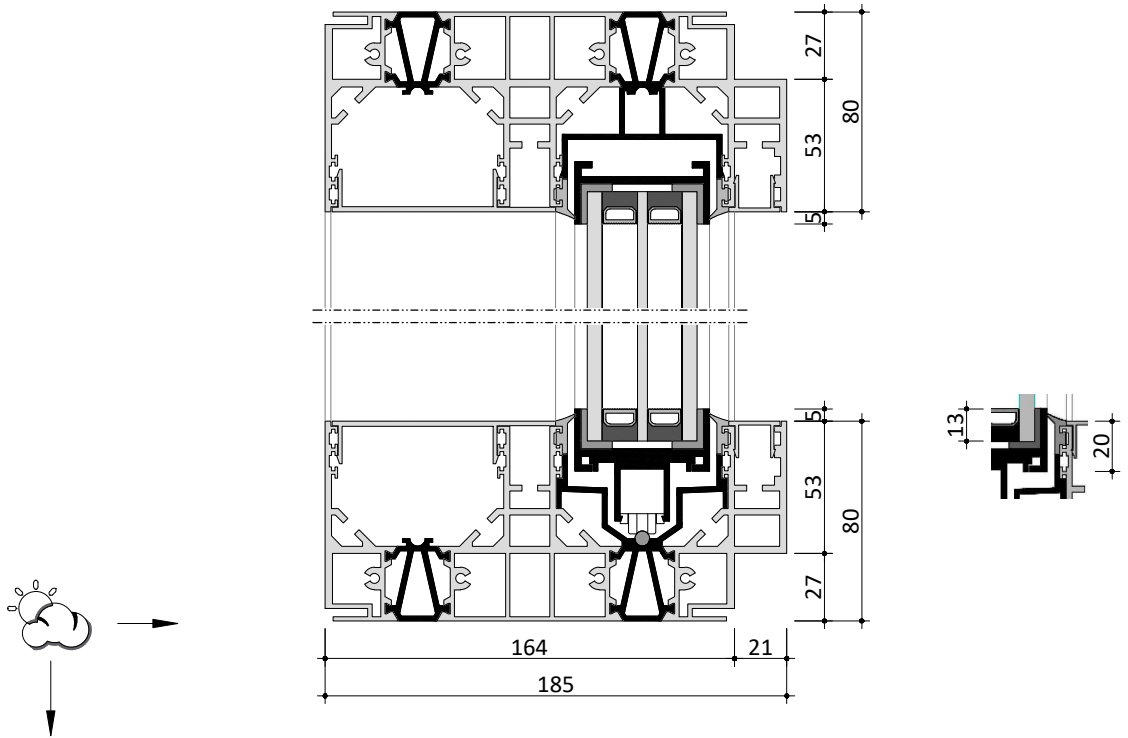
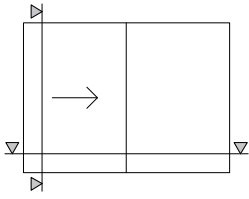



M 1:3

view - fix - locking groove

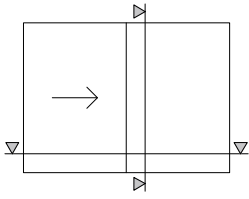

	G1	G2
34mm	15 mm	15 mm
35mm	14 mm	15 mm
36mm	14 mm	15 mm
37mm	13 mm	15 mm
38mm	13 mm	13 mm
39mm	12 mm	13 mm
40mm	12 mm	13 mm
41mm	11 mm	13 mm
42mm	11 mm	11 mm
43mm	10 mm	11 mm
44mm	10 mm	11 mm

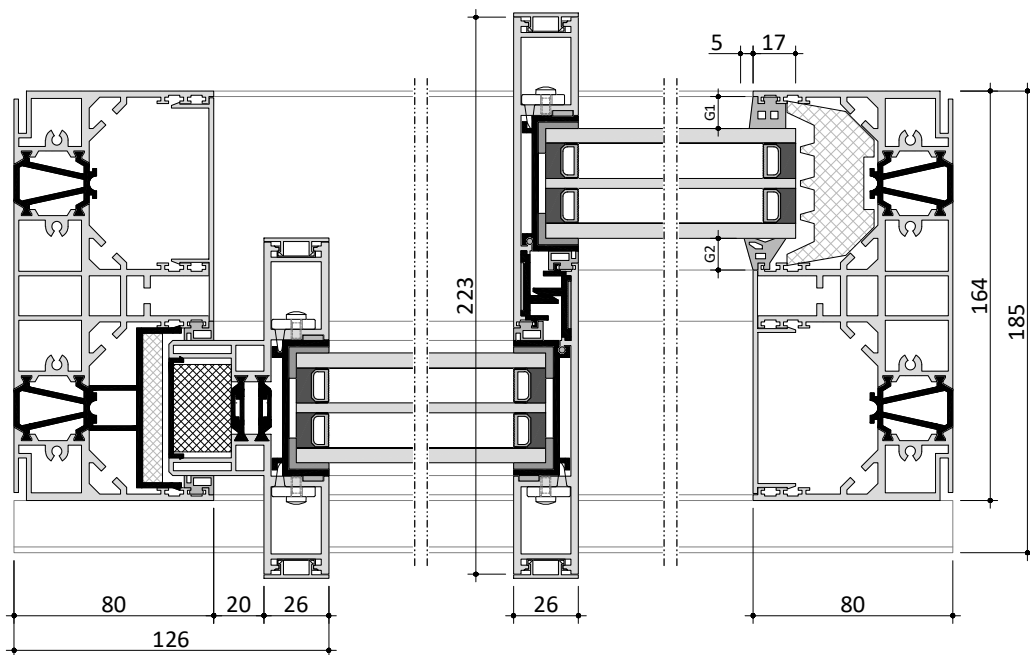
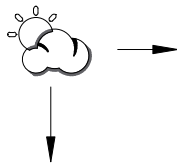
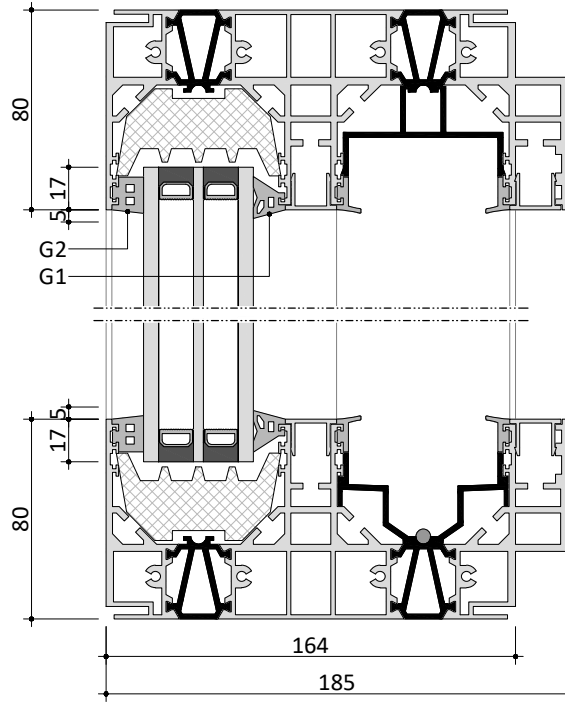

M 1:3

floor PL - sliding

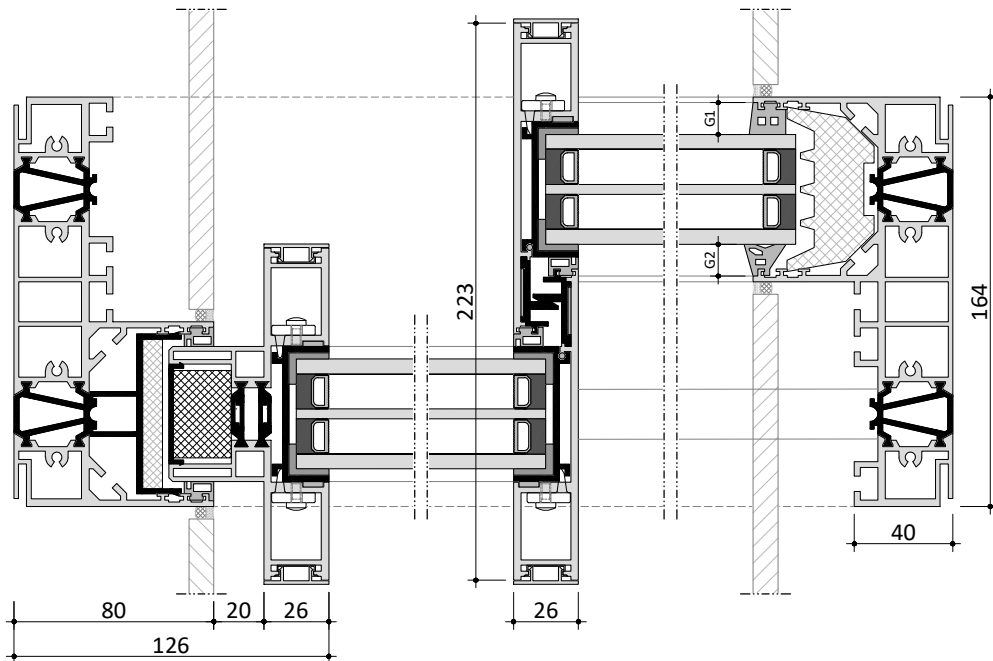
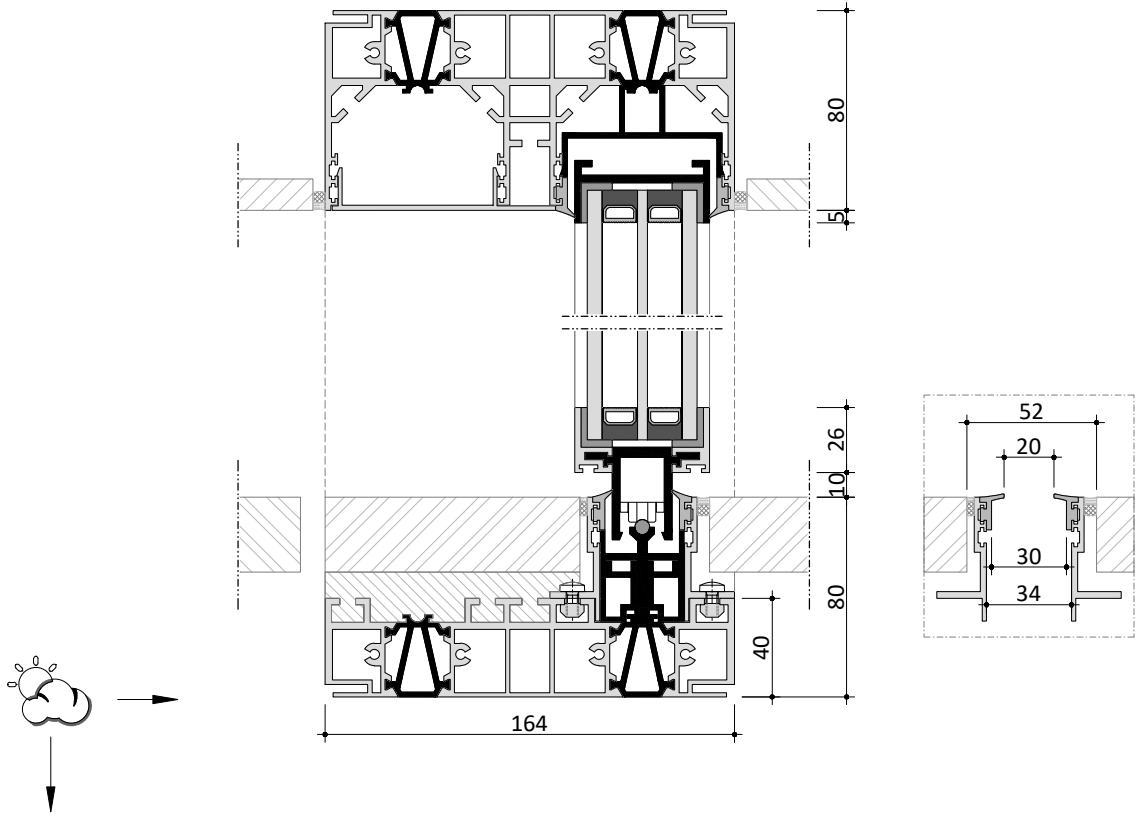
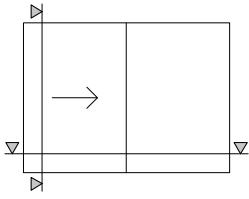

M 1:3

floor CL - sliding

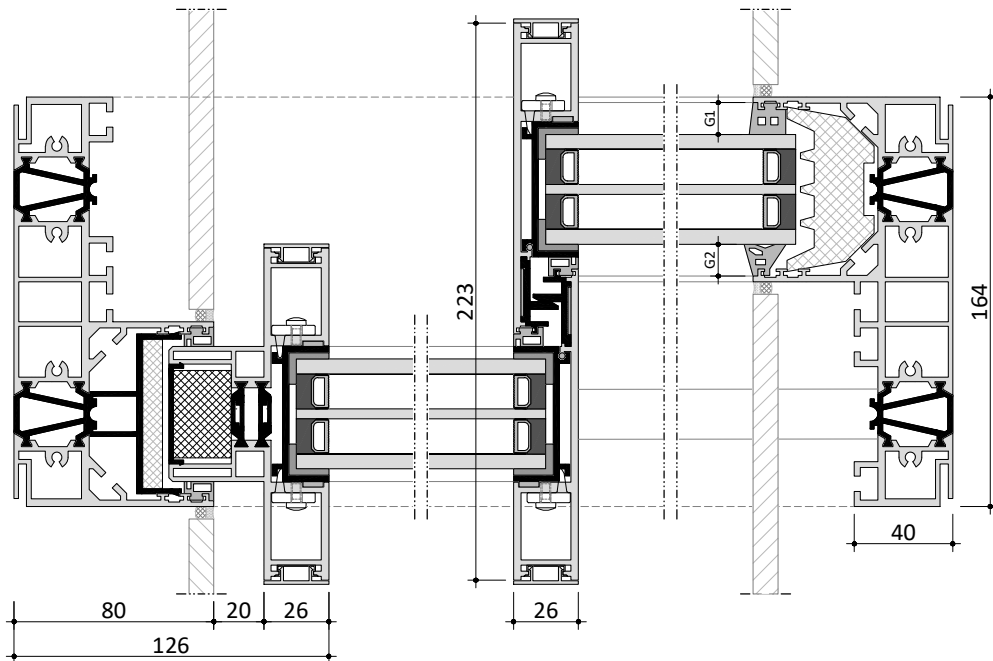
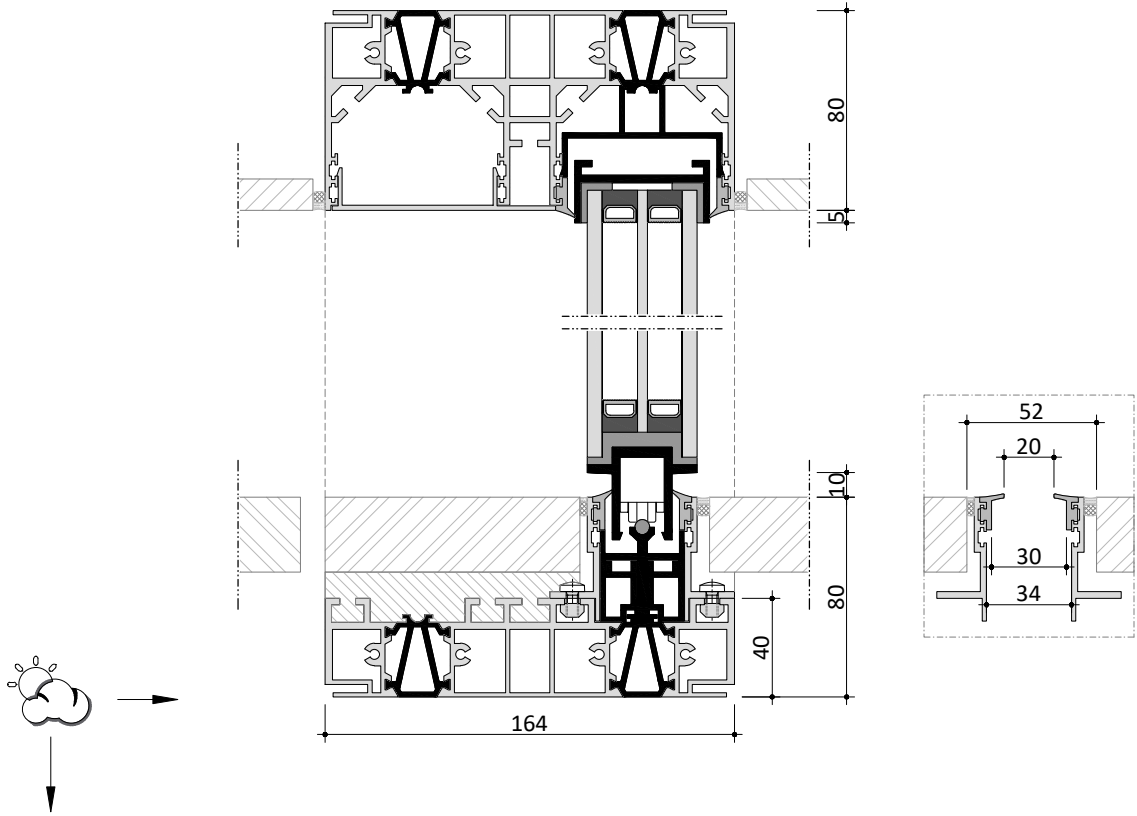
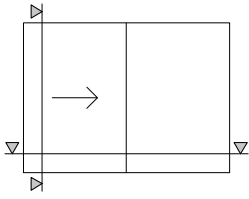

M 1:3

floor CL/PL - fix

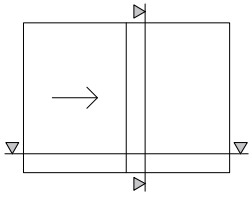

	G1	G2
34mm	15 mm	15 mm
35mm	14 mm	15 mm
36mm	14 mm	15 mm
37mm	13 mm	15 mm
38mm	13 mm	13 mm
39mm	12 mm	13 mm
40mm	12 mm	13 mm
41mm	11 mm	13 mm
42mm	11 mm	11 mm
43mm	10 mm	11 mm
44mm	10 mm	11 mm

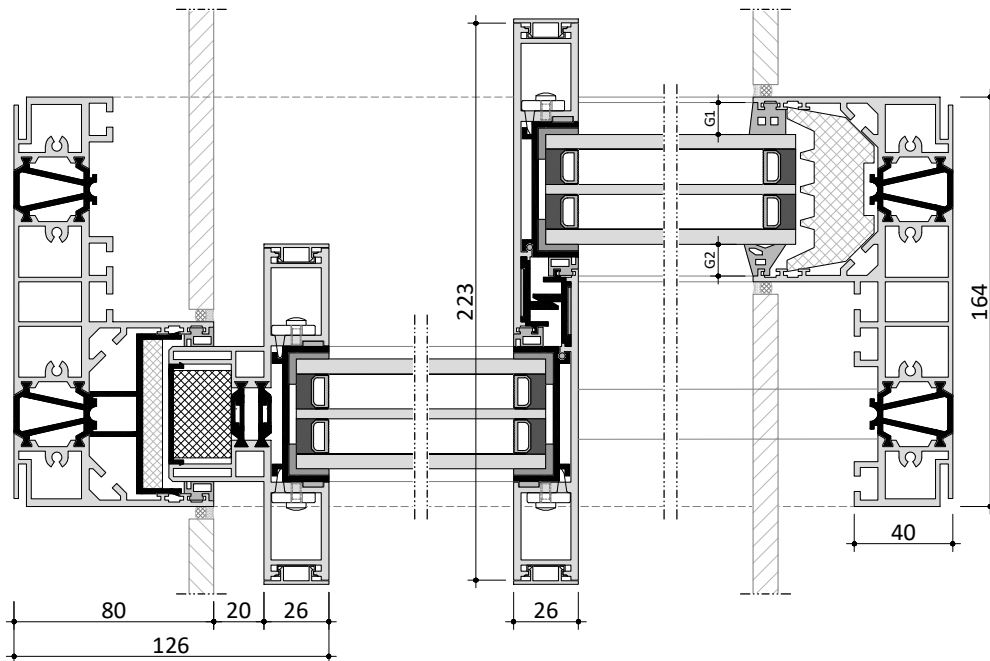
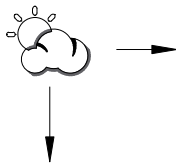
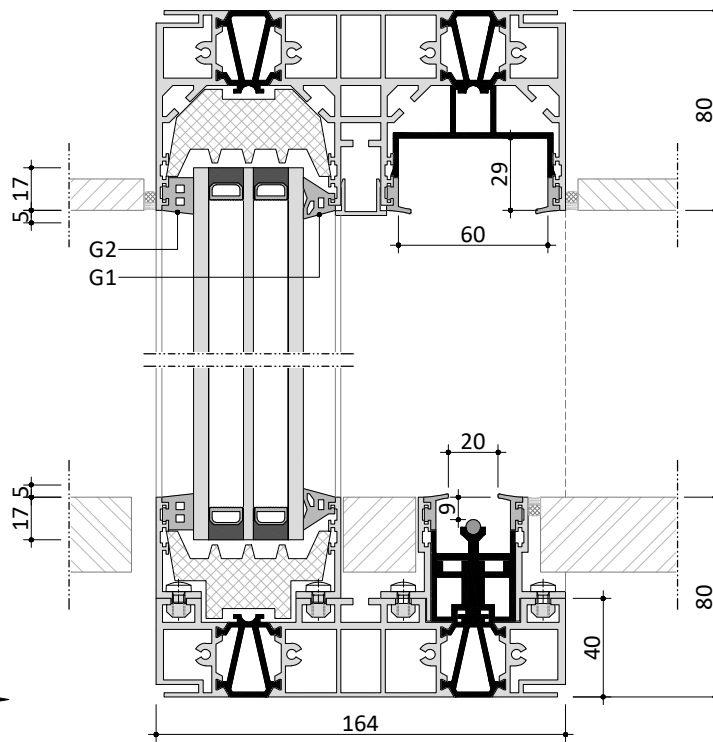



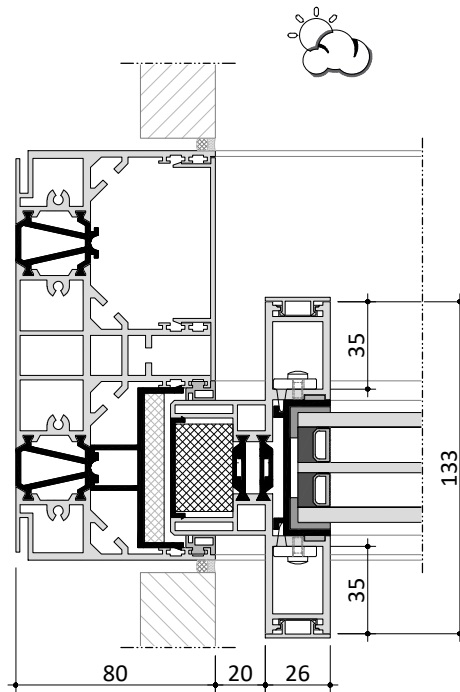
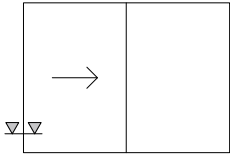

G4

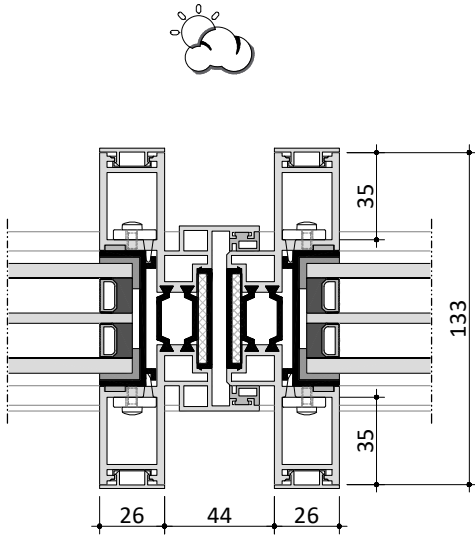
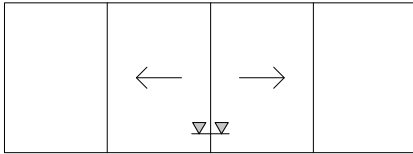

**ST4 - G4S**

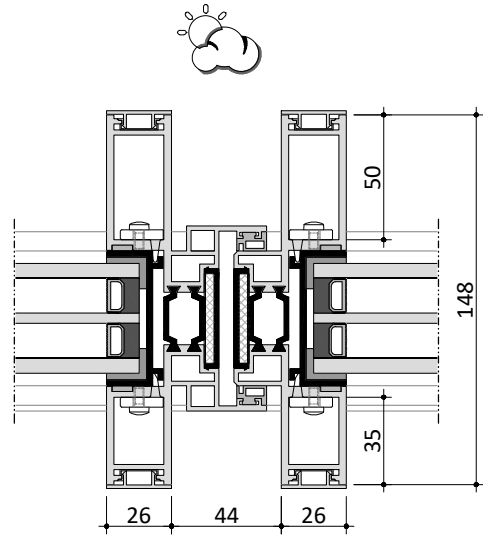

**ST5 - G5S**

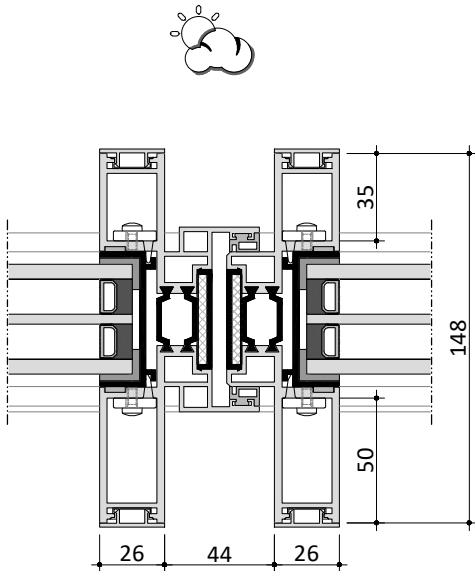

**ST6 - G6S**

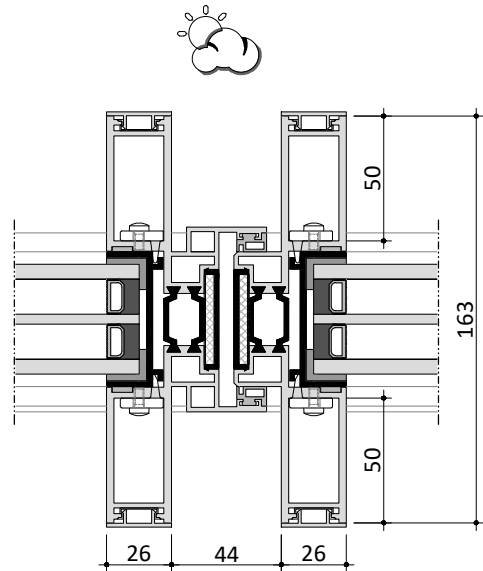

**ST7 - G7S**

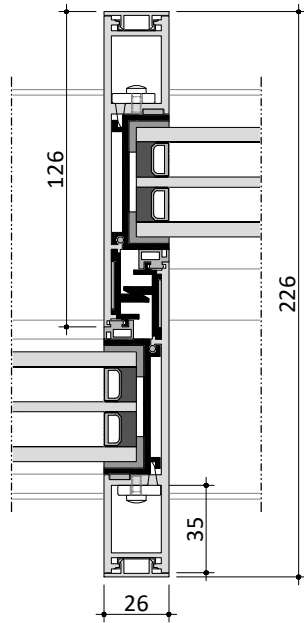
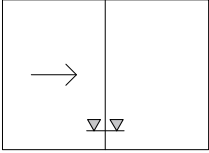

ZK-1

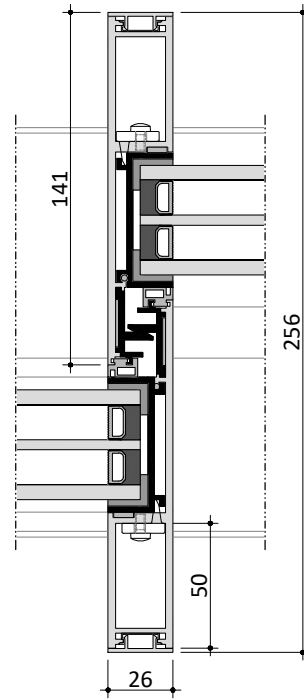

ZK-2



type 1



type 1a



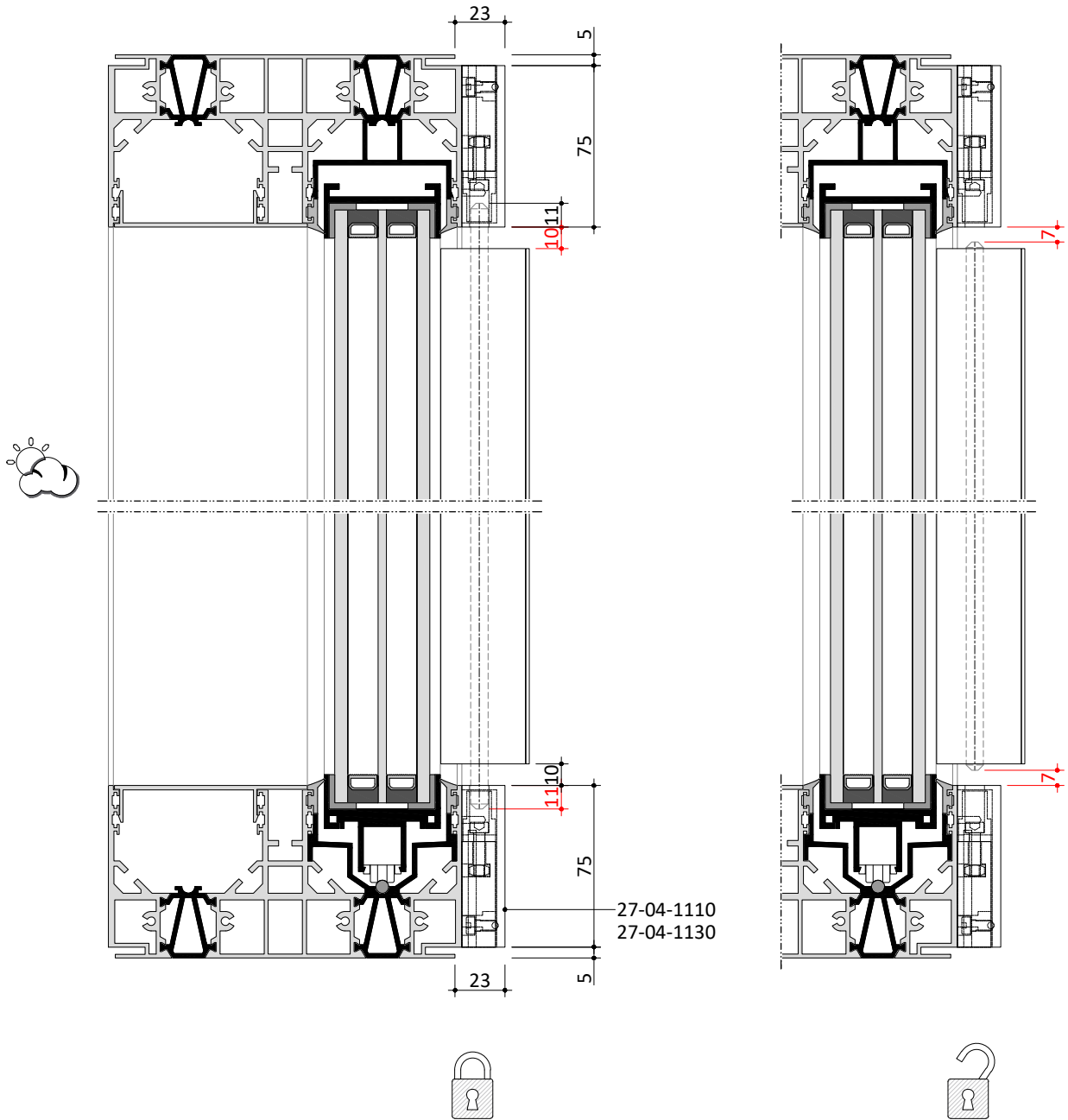

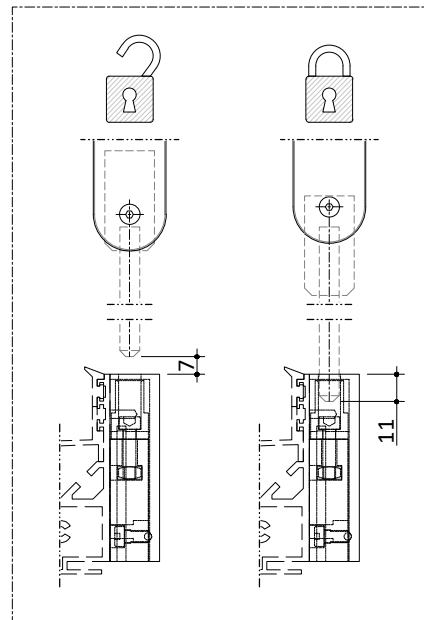
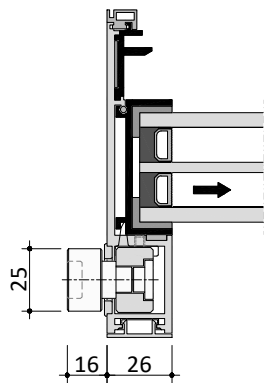
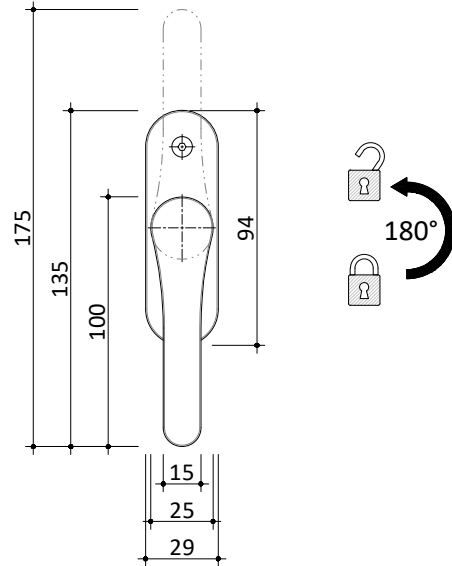
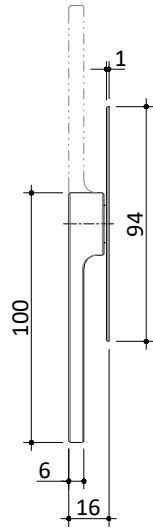

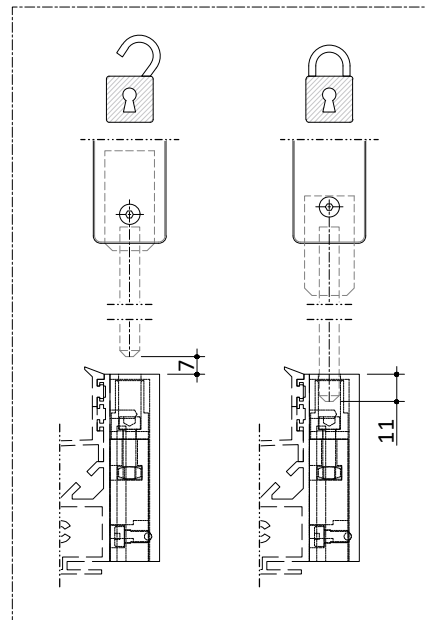
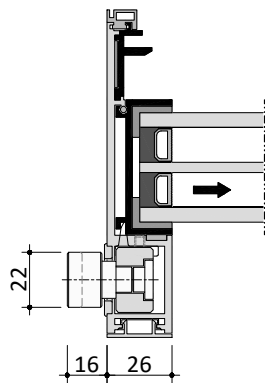
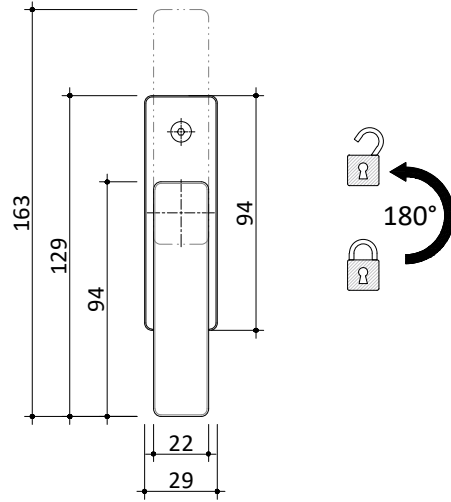
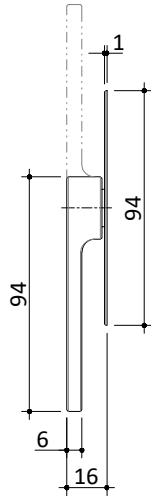

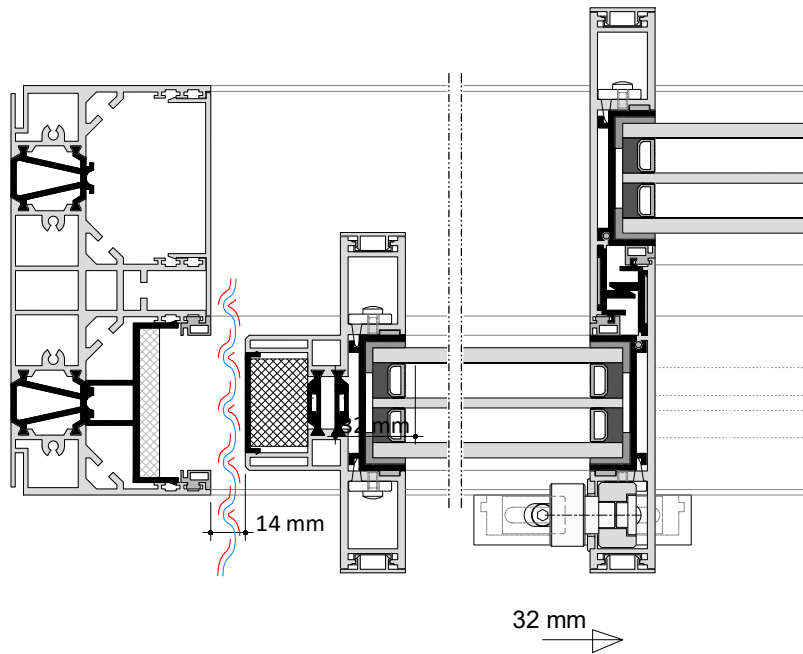
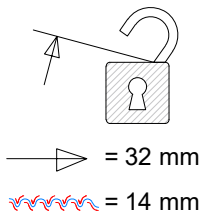
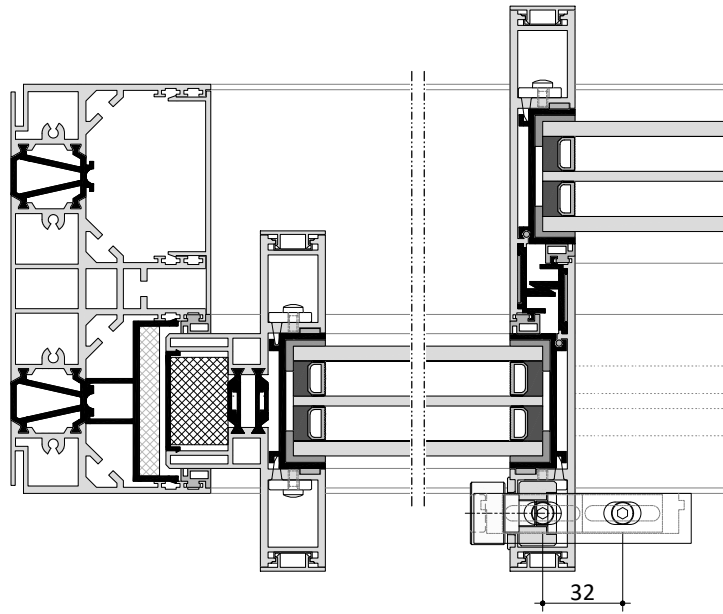



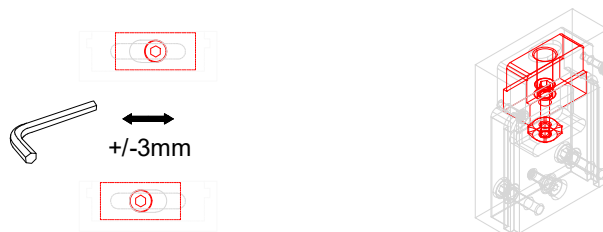
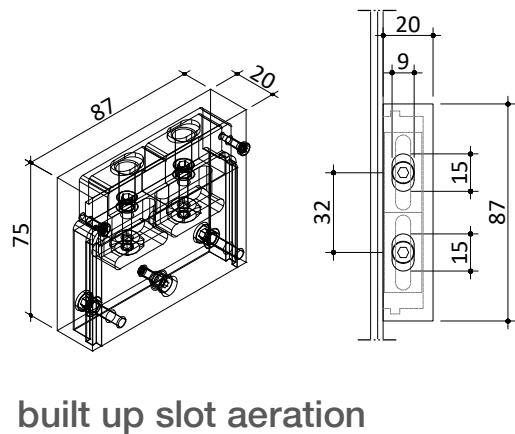
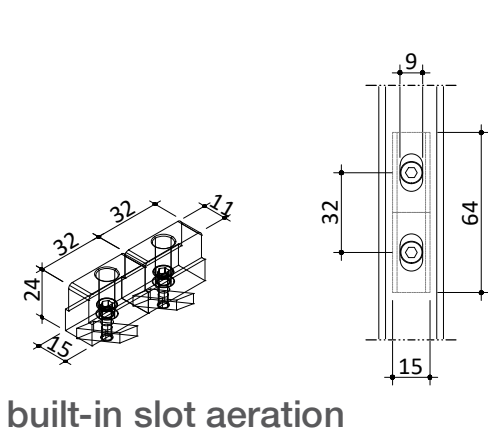
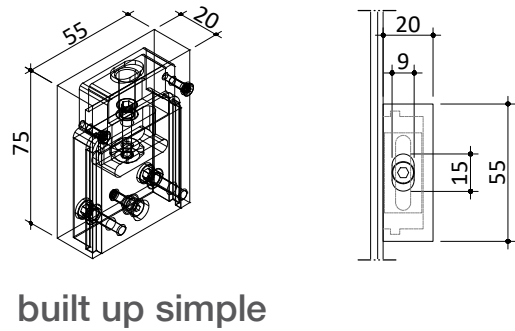
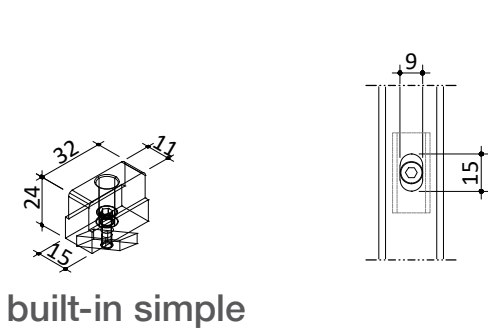
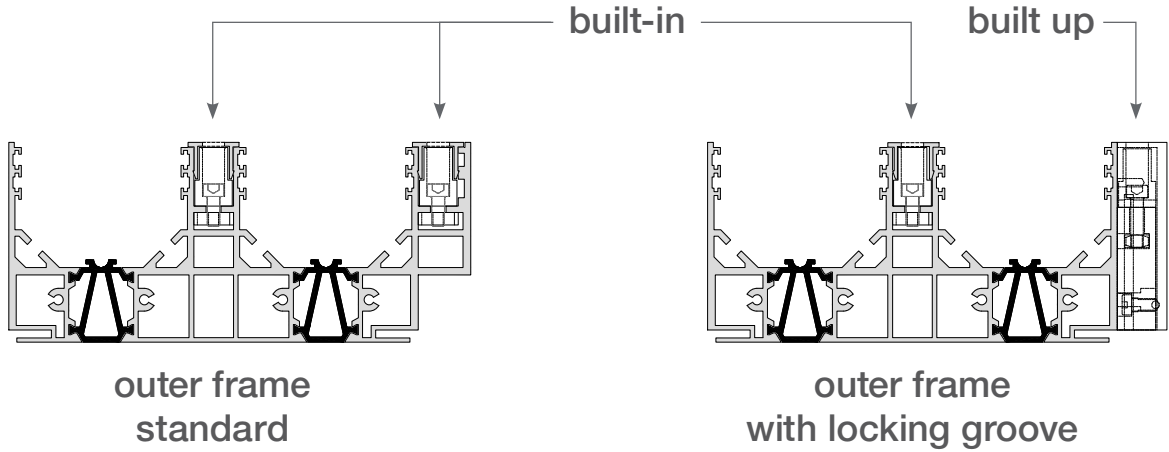

**adjustment +/-3 mm (\*)**

(\*) even after full installation and finish

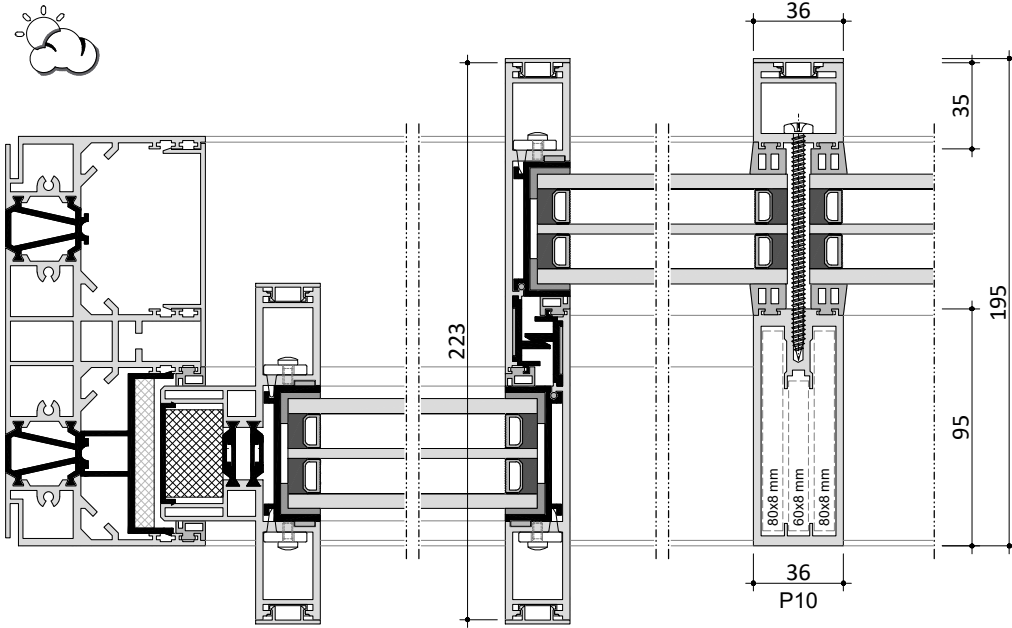
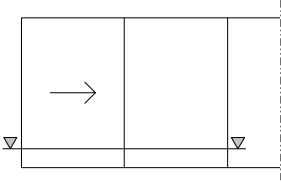

- 30-01-060x08 (alu)  
60x8 mm
- 34-01-060x08 (stainless steel)  
60x8 mm
- 30-01-080x08 (alu)  
80x8 mm
- 34-01-080x08 (stainless steel)  
80x8 mm

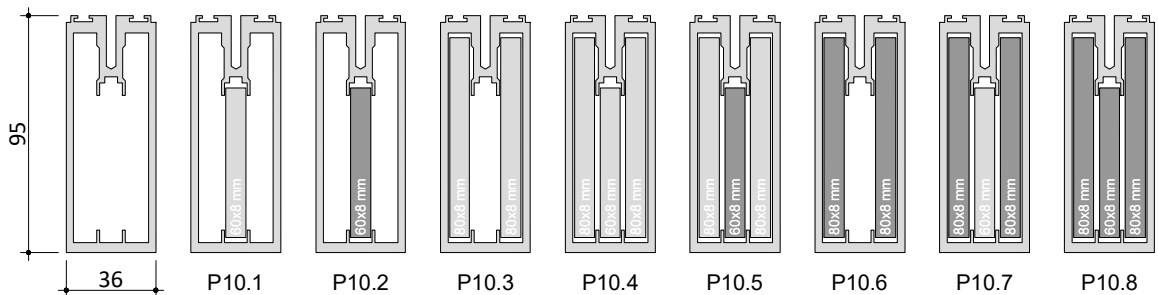

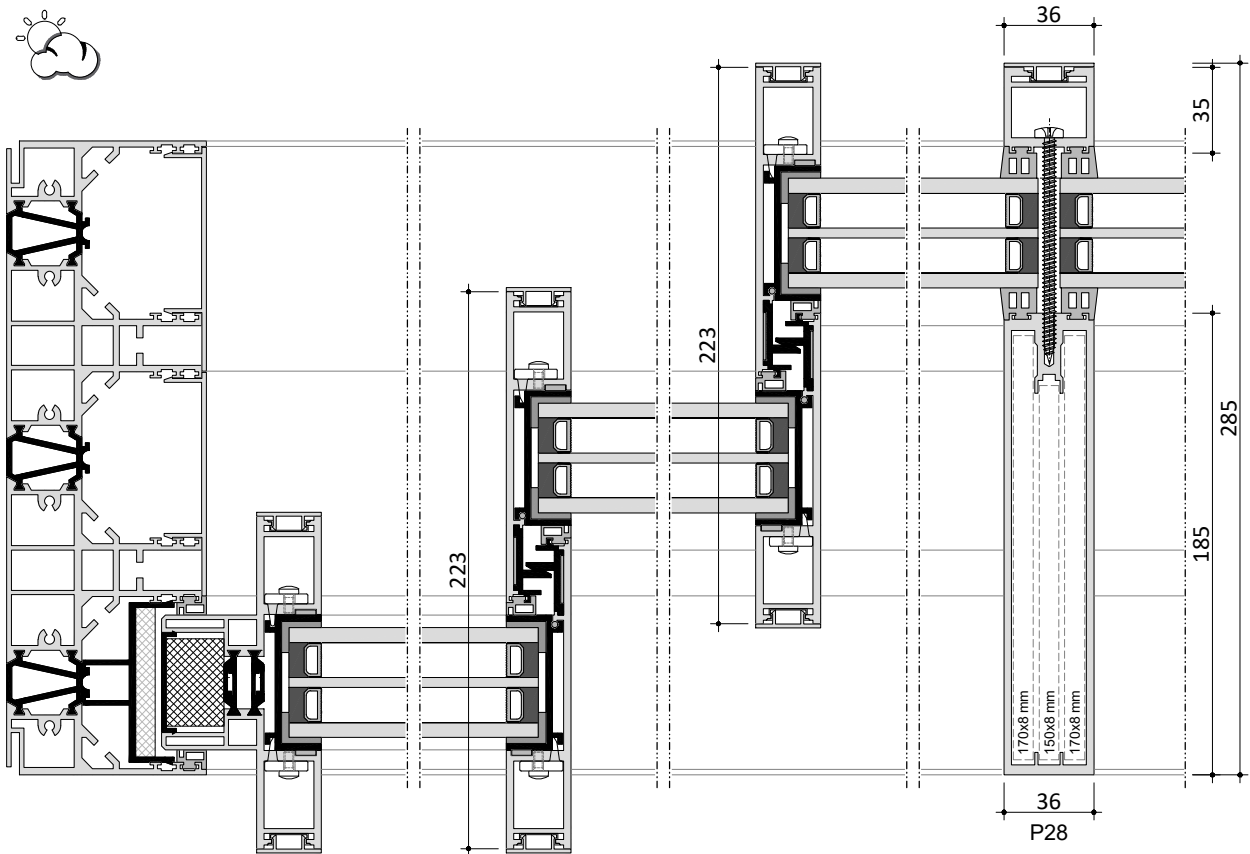
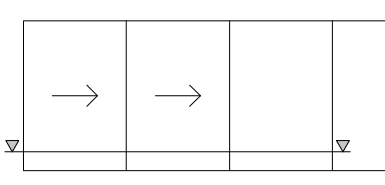

30-01-150x08 (alu)

150x8 mm

34-01-150x08 (stainless steel)

150x8 mm

30-01-170x08 (alu)

170x8 mm

34-01-170x08 (stainless steel)

170x8 mm

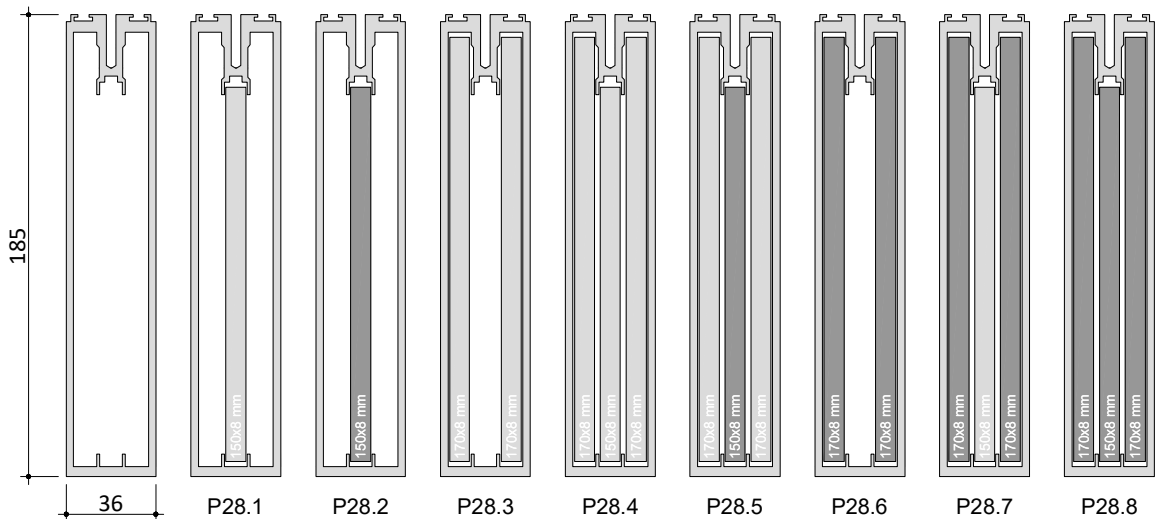

LEGENDE

- F = Outer frame dimensions
- L = Leaf dimensions
- G = Glass dimensions
- A = Axis

ELEMENTS

03-a1

view • 1x fix 1R & 2x fix highline 2R

M 1:3

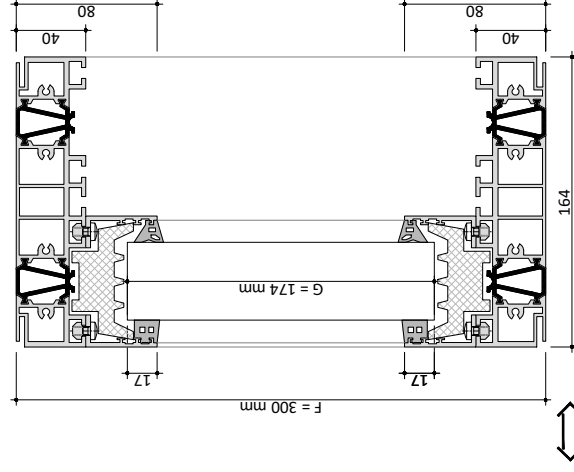
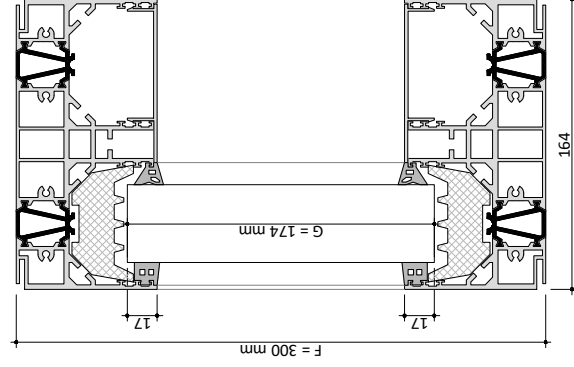
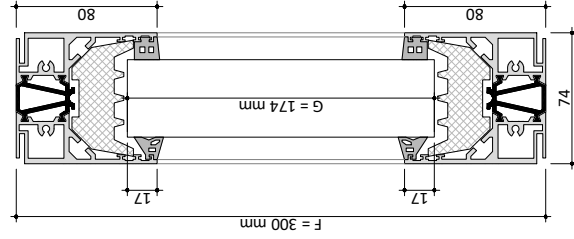
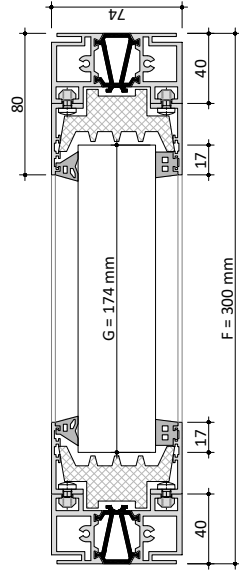
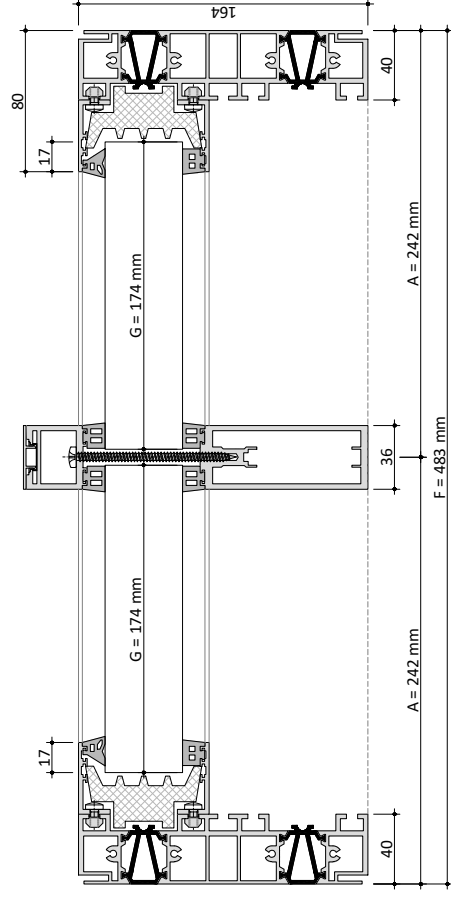

The main purpose of this cross-section is that the compositions are drawn and that the cross-sections are made to the desired size in AutoCAD by means of stretching.



Architect manual



NGS4

LEGENDE

- F = Outer frame dimensions
- L = Leaf dimensions
- G = Glass dimensions
- A = Axis

ELEMENTS

view • SF

M 1:3

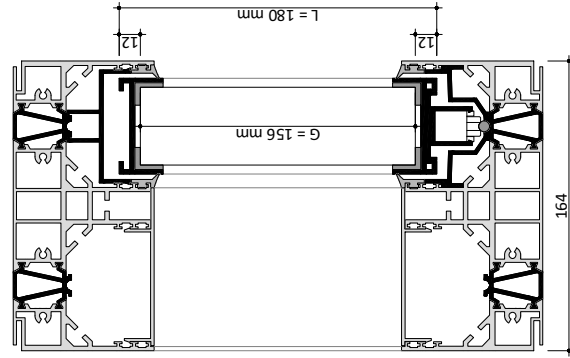
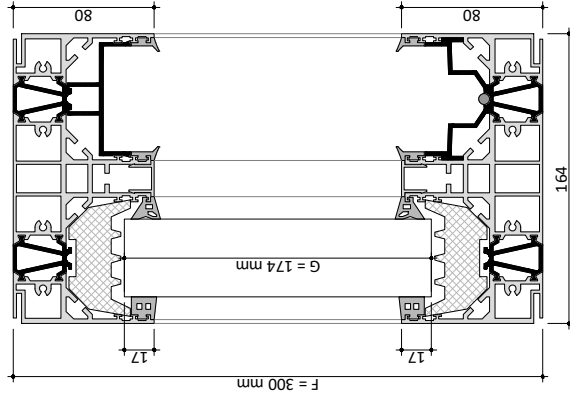
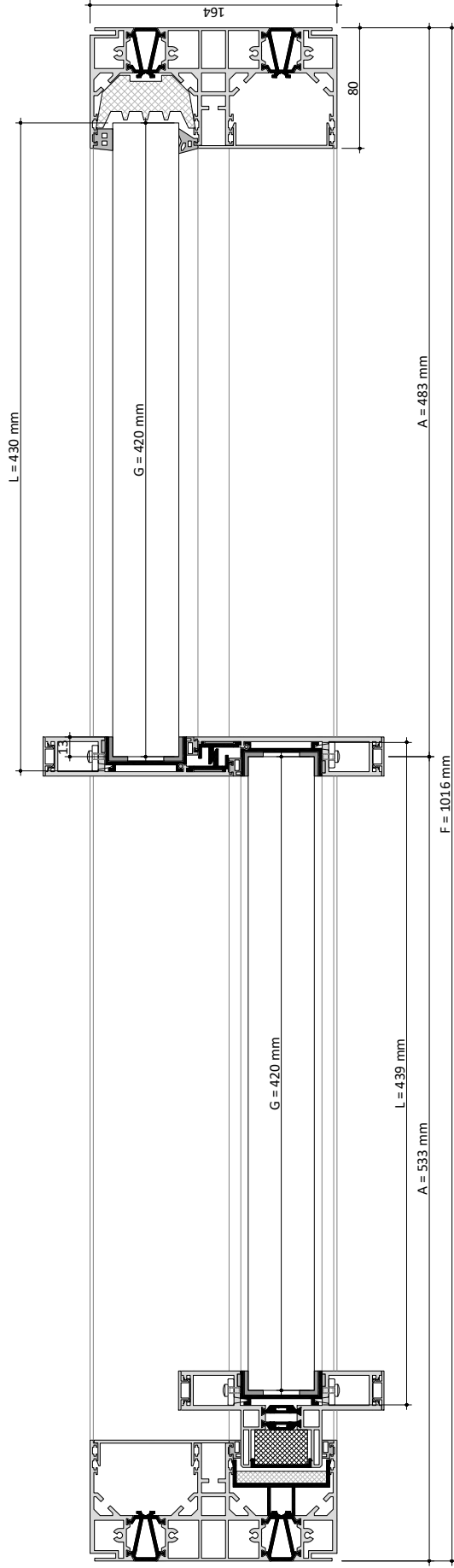

The main purpose of this cross-section is that the compositions are drawn and that the cross-sections are made to the desired size in AutoCAD by means of stretching.



Architect manual



NGS4

LEGENDE

- F = Outer frame dimensions
- L = Leaf dimensions
- G = Glass dimensions
- A = Axis

ELEMENTS

view • SS

M 1:3

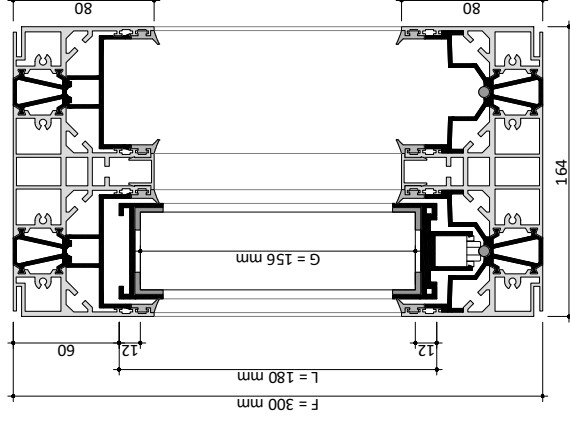
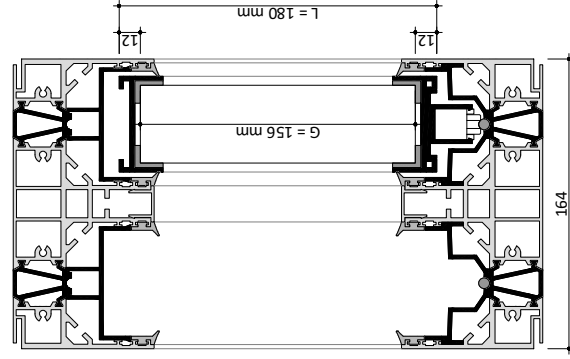
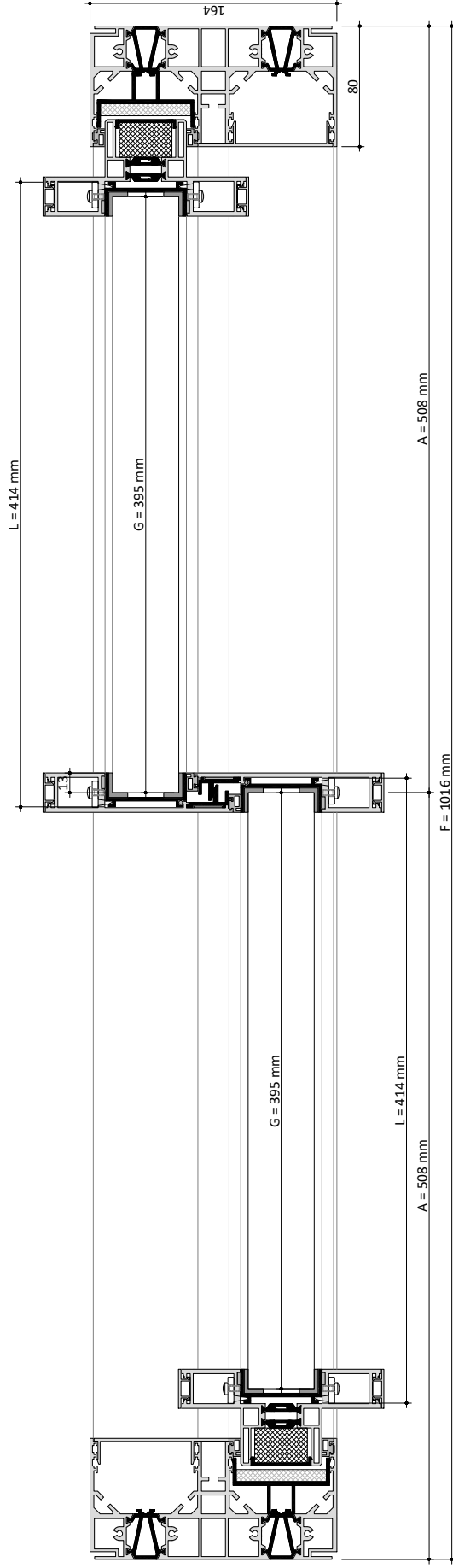

The main purpose of this cross-section is that the compositions are drawn and that the cross-sections are made to the desired size in AutoCAD by means of stretching.



Architect manual



NGS4

Keller minimal windows® • 06/2023

03-a3

LEGENDE

- F = Outer frame dimensions
- L = Leaf dimensions
- G = Glass dimensions
- A = Axis

ELEMENTS

03-a4

view • FSSF (2R) double vent

M 1:3

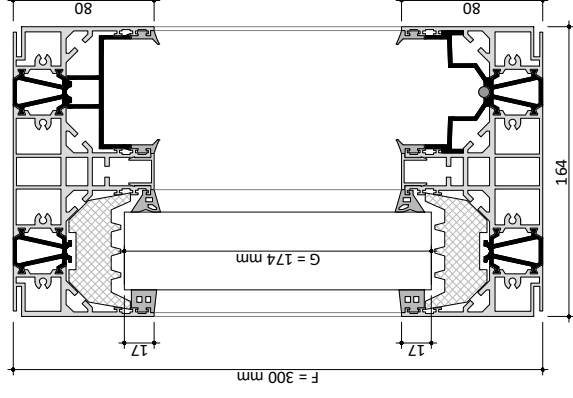
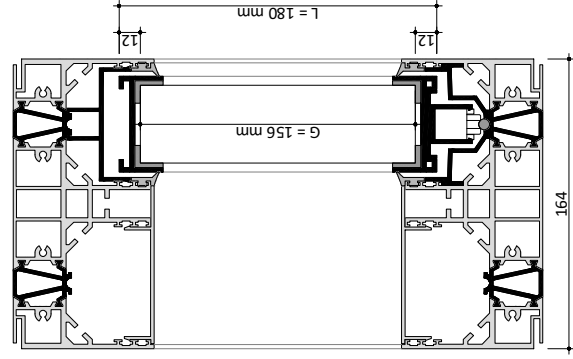
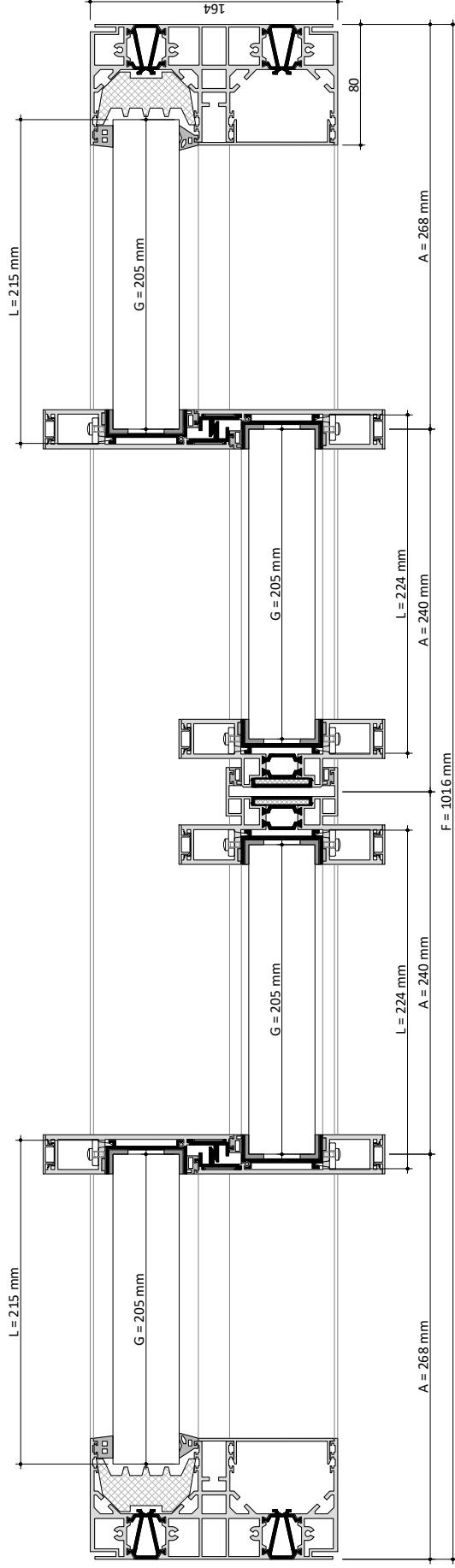

The main purpose of this cross-section is that the compositions are drawn and that the cross-sections are made to the desired size in AutoCAD by means of stretching.



Architect manual



NGS4

Keller minimal windows® • 06/2023



LEGENDE

- F = Outer frame dimensions
- L = Leaf dimensions
- G = Glass dimensions
- A = Axis

ELEMENTS

03-a5

view • SSSS (2R) double vent

M 1:3

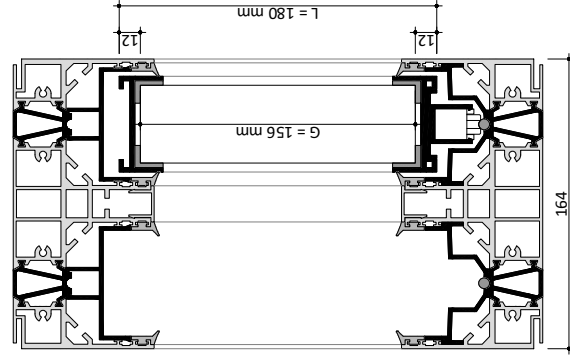
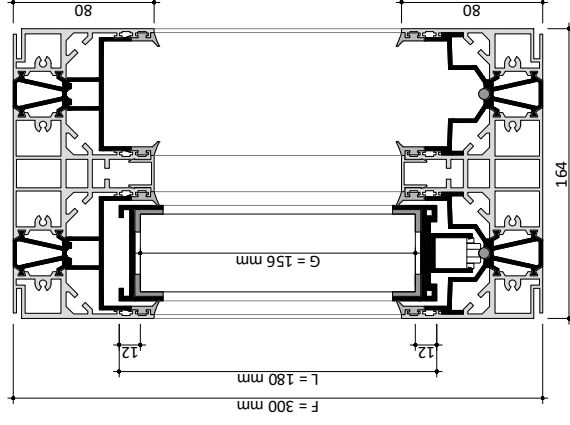
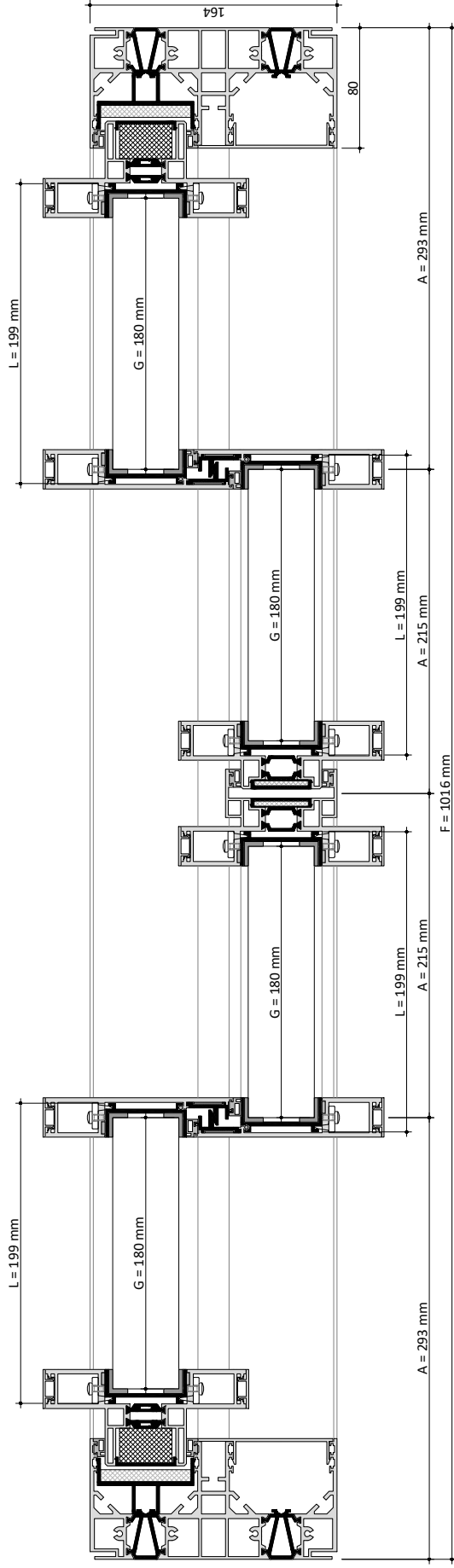

The main purpose of this cross-section is that the compositions are drawn and that the cross-sections are made to the desired size in AutoCAD by means of stretching.



Architect manual



NGS4

Keller minimal windows® • 06/2023

LEGENDE

- F = Outer frame dimensions
- L = Leaf dimensions
- G = Glass dimensions
- A = Axis

ELEMENTS

view • SSF (3R)

M 1:3

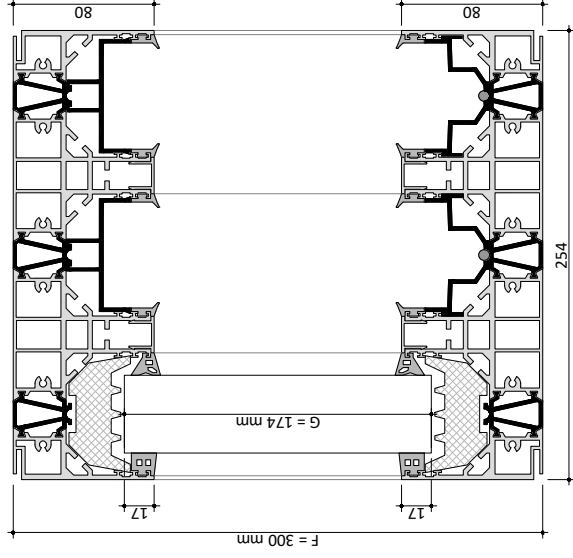
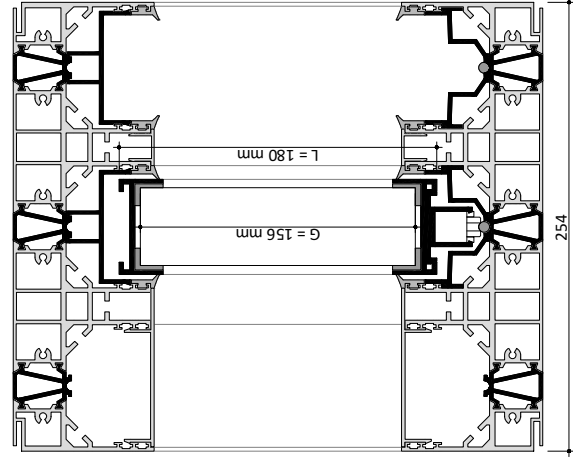
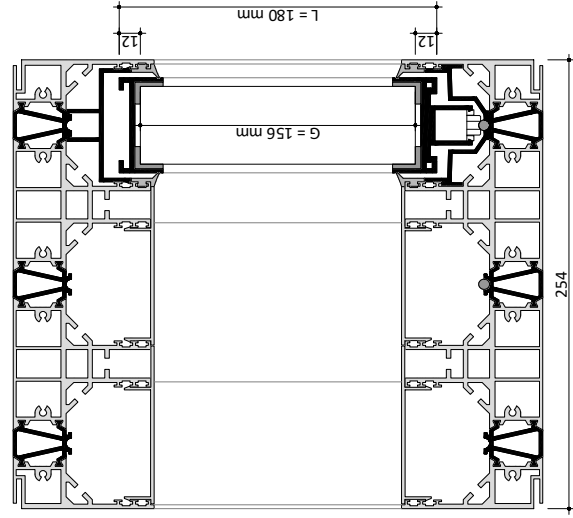
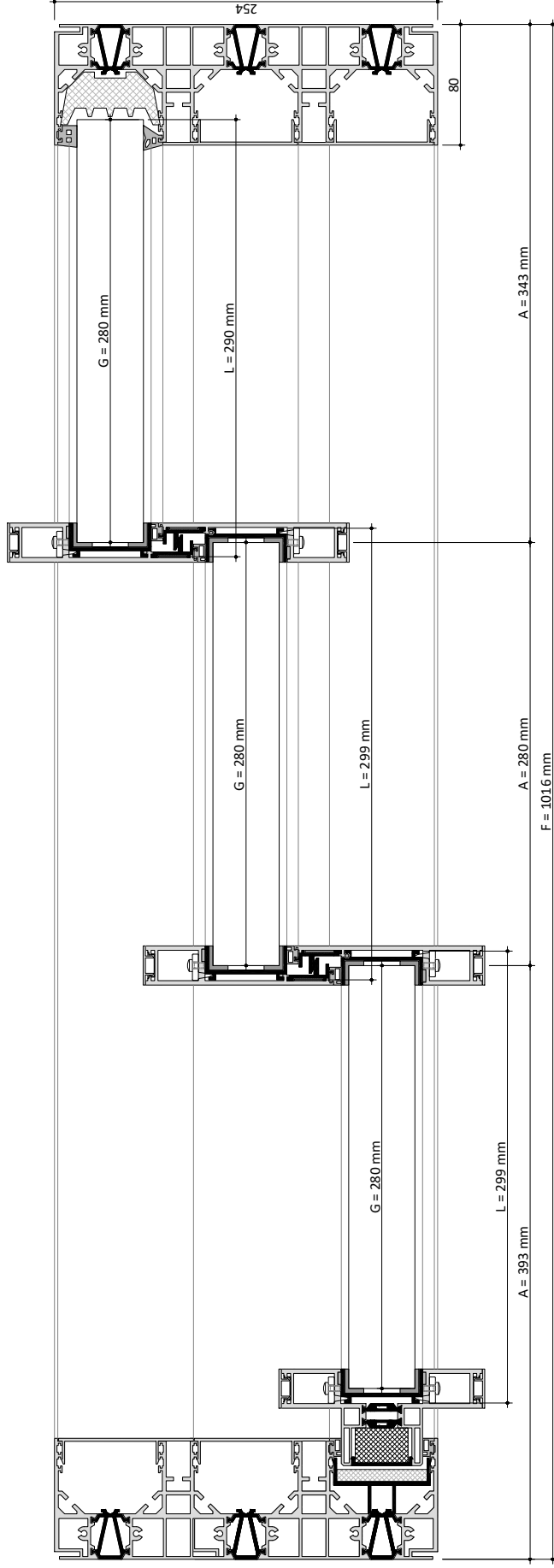

The main purpose of this cross-section is that the compositions are drawn and that the cross-sections are made to the desired size in AutoCAD by means of stretching.



LEGENDE

- F = Outer frame dimensions
- L = Leaf dimensions
- G = Glass dimensions
- A = Axis

ELEMENTS

view • SSS (3R)

M 1:3

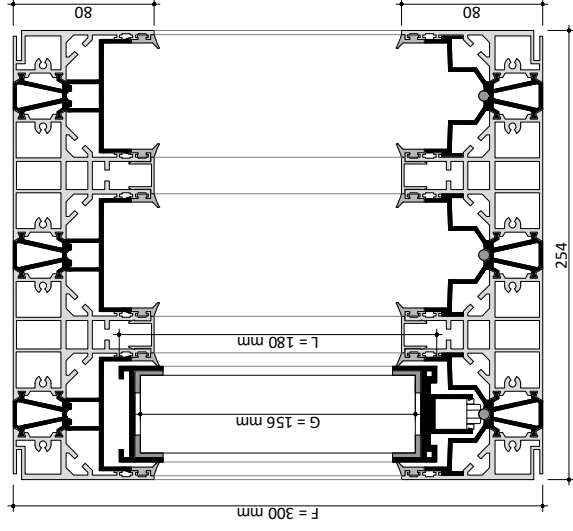
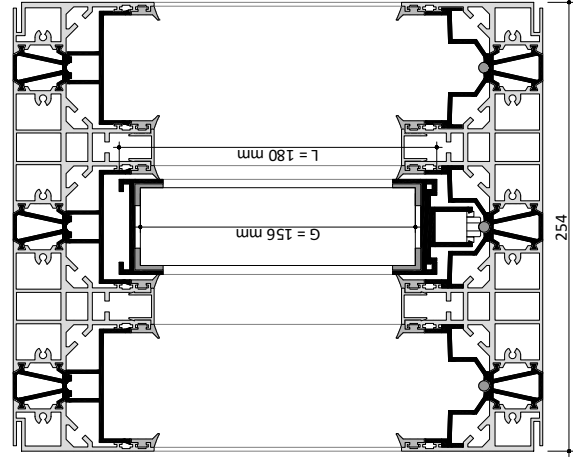
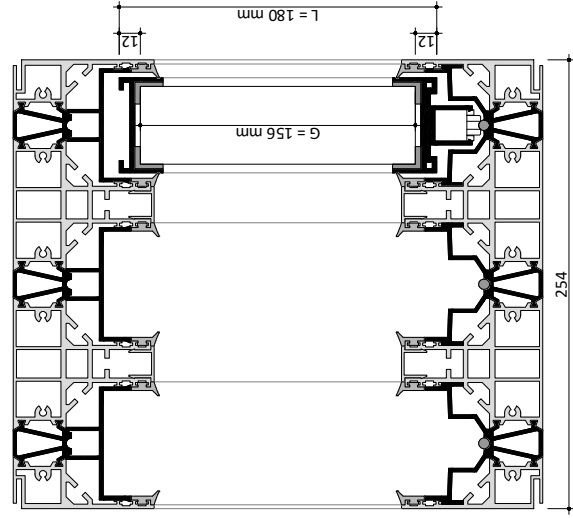
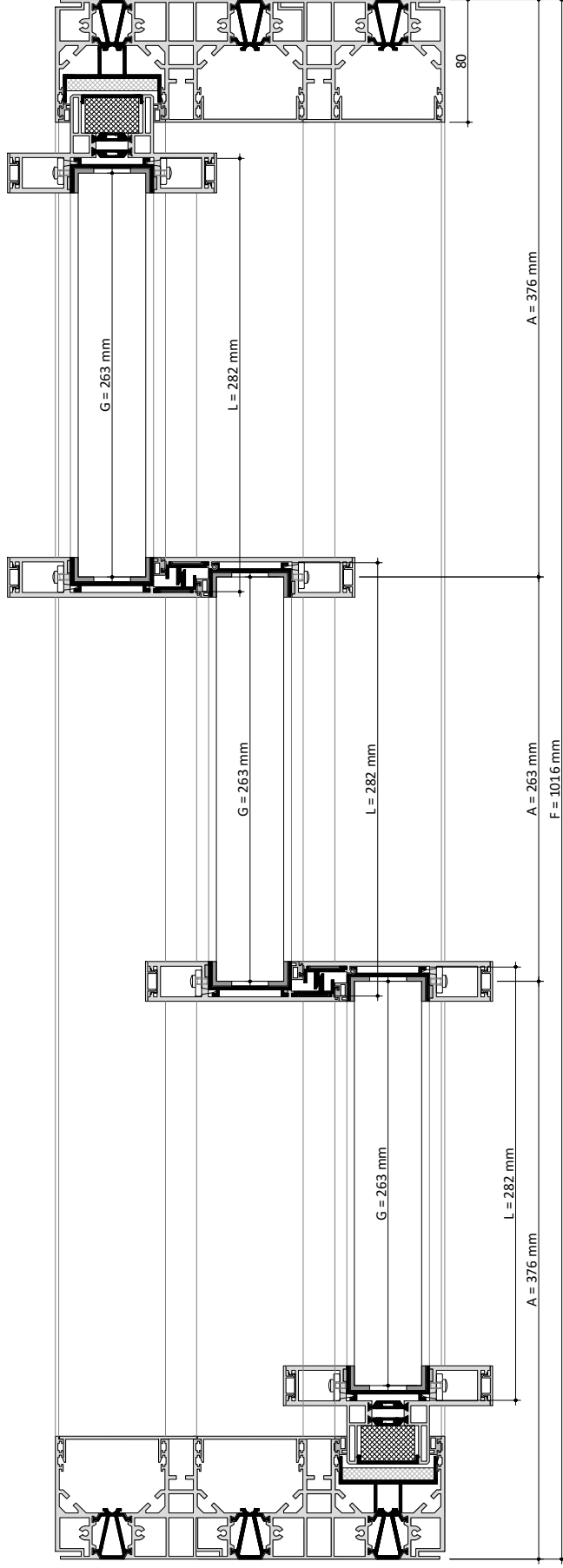

The main purpose of this cross-section is that the compositions are drawn and that the cross-sections are made to the desired size in AutoCAD by means of stretching.



### 1 Leaf

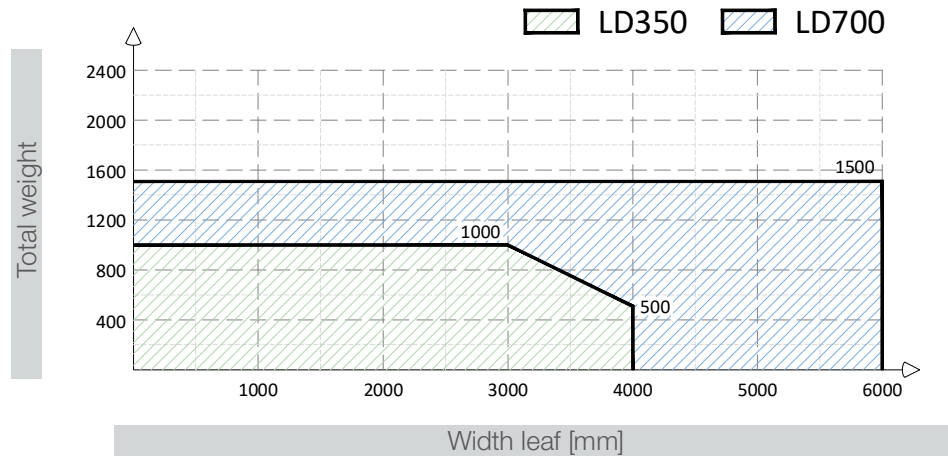

### 2 Leaf

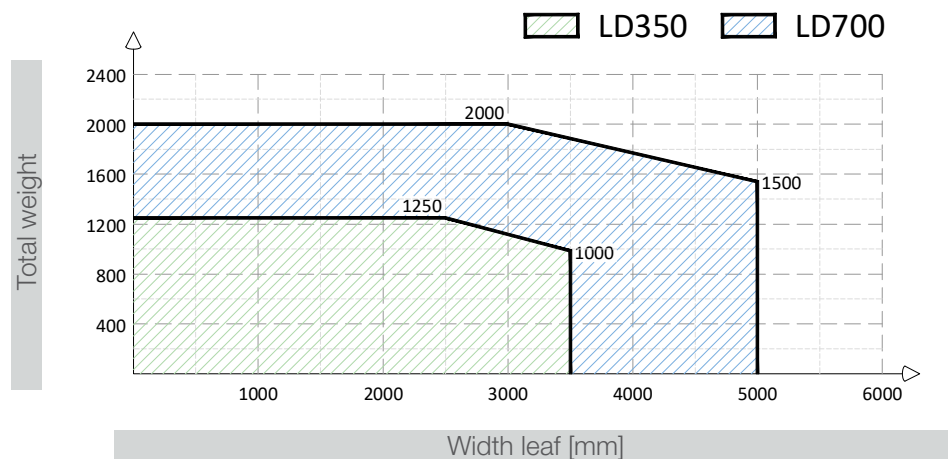

### 3 Leaf

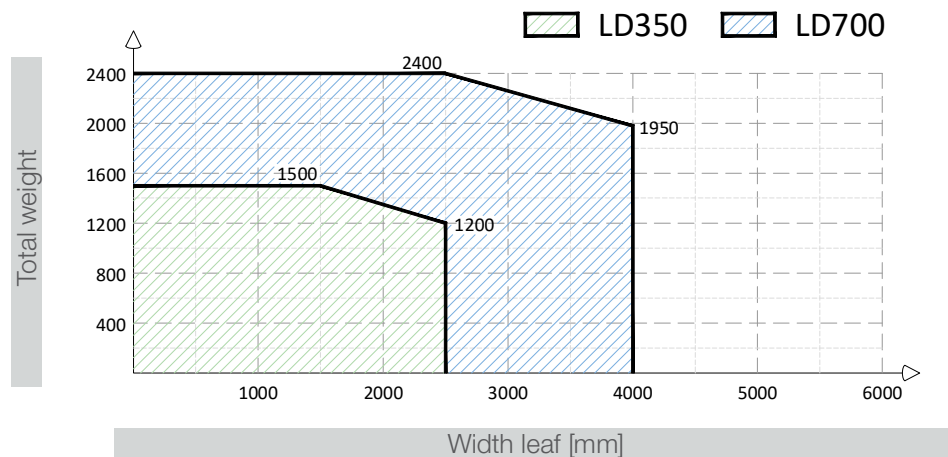

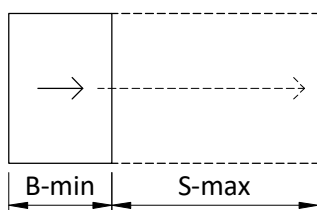
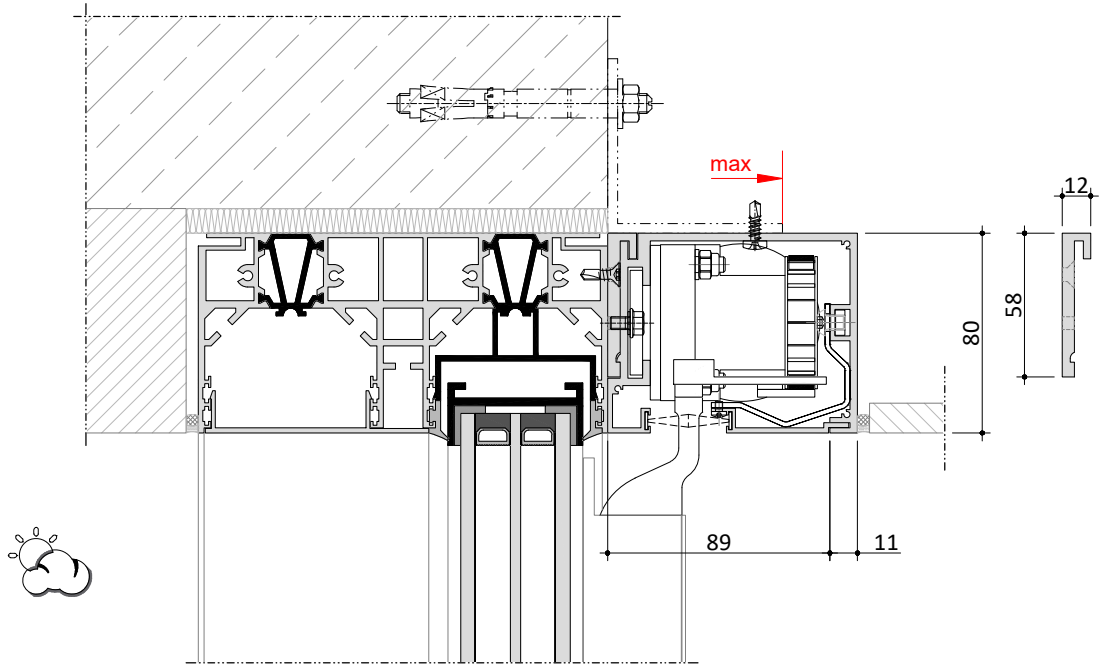
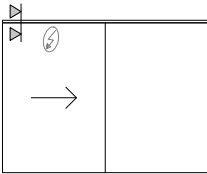

<b>B-min</b>		
LD350	=	1.400 mm
LD700	=	1.400 mm
<b>S-Max =</b>		
LD350	=	10.000 mm
LD700	=	12.000 mm

(\*) Measures with equal glass dimensions

**Without electrical opening**

- A = 60 mm
- B = 20 mm
- C = 75 mm

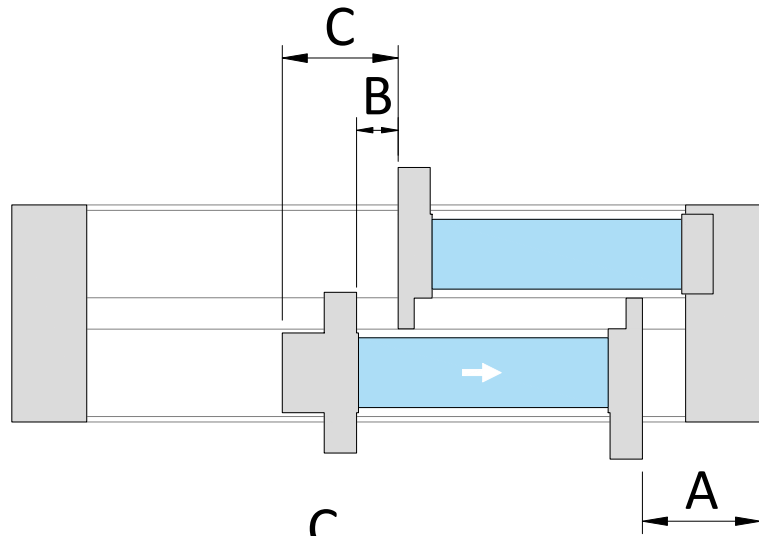

**With LD350**

- A = 130 mm
- B = 90 mm
- C = 145 mm

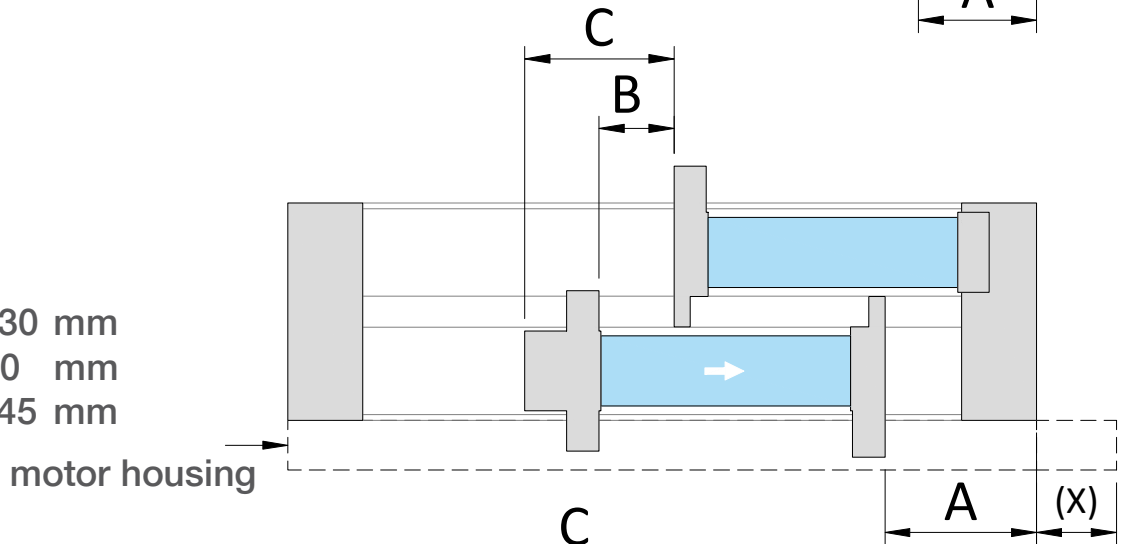

**With LD700**

- A = 310 mm
- B = 270 mm
- C = 325 mm

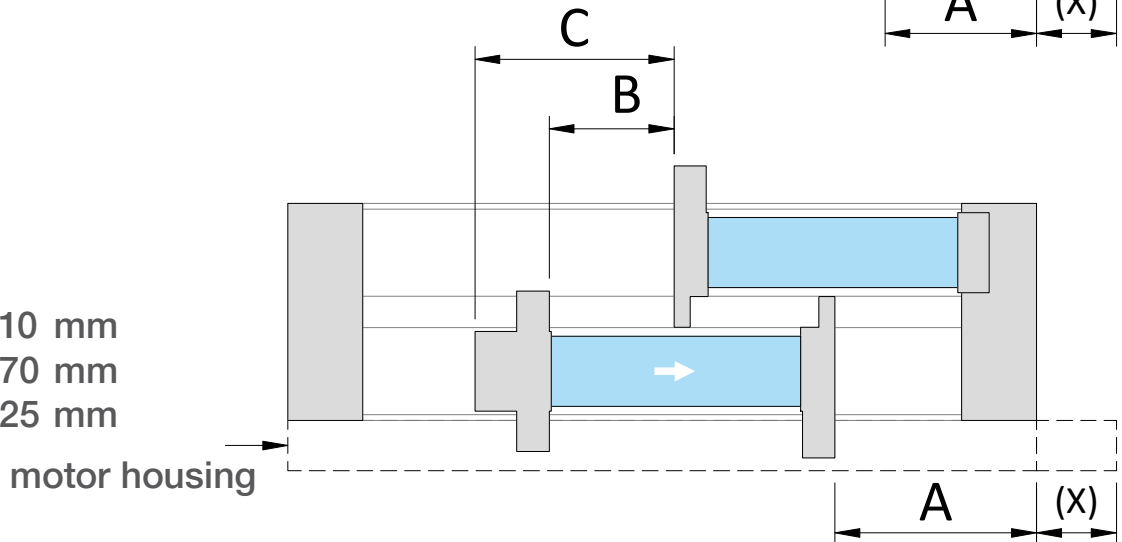

Dimensions A-B-C can be reduced if the motor housing is longer (X) than the sliding window.

M 1:3

smart slider - top drive

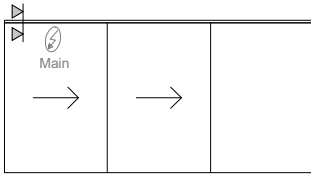

1 drive moving several leaves

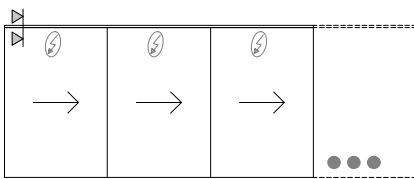
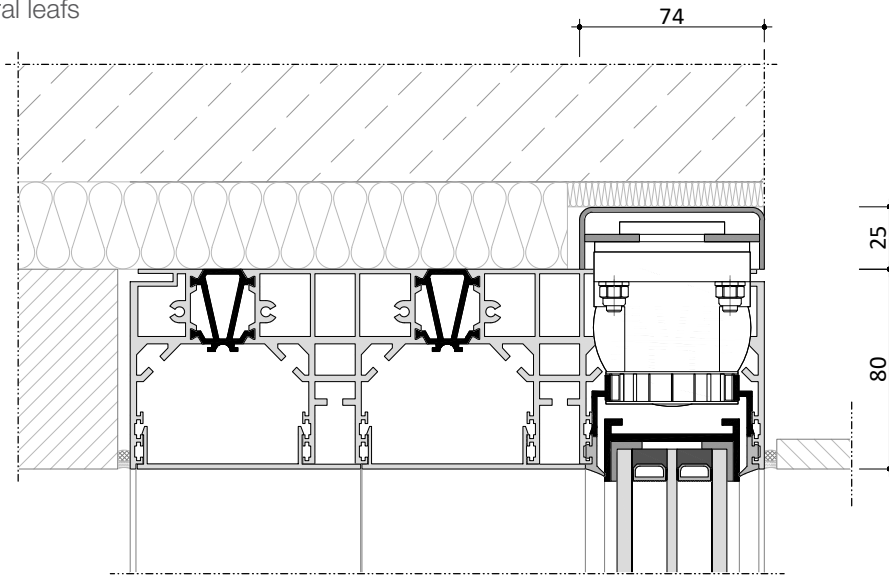

1 drive / leaf & moving synchronic

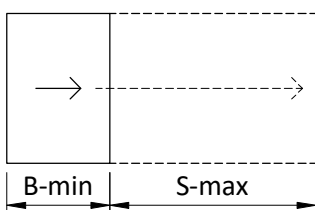
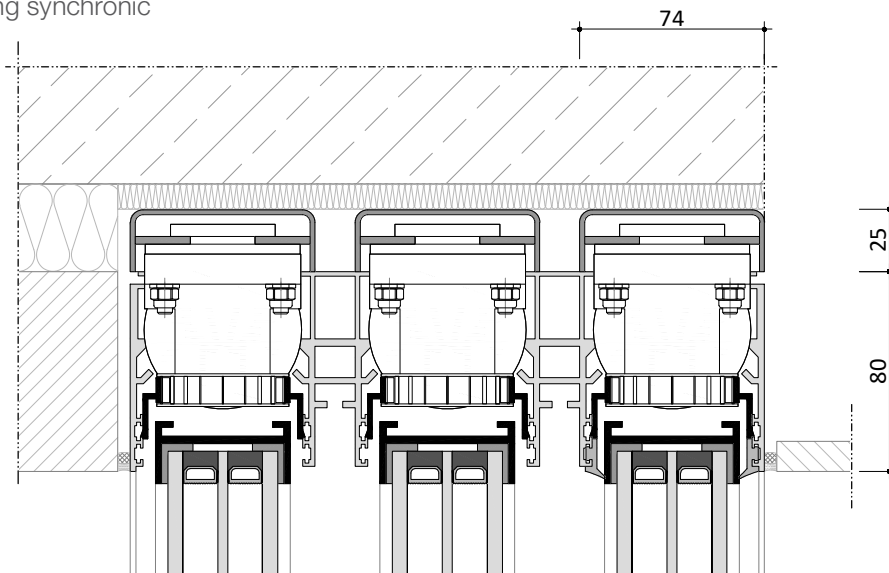

<b>B-min</b>	
LD350	= 1.550 mm
LD700	= 1.840 mm
<b>S-Max =</b>	
LD350	= 10.000 mm
LD700	= 12.000 mm



M 1:3

Opening width of the drive way (\*)

(\*) Measures with equal glass dimensions

**With LD350**

- A = 100 mm
- B = 20 mm
- C = 88 mm

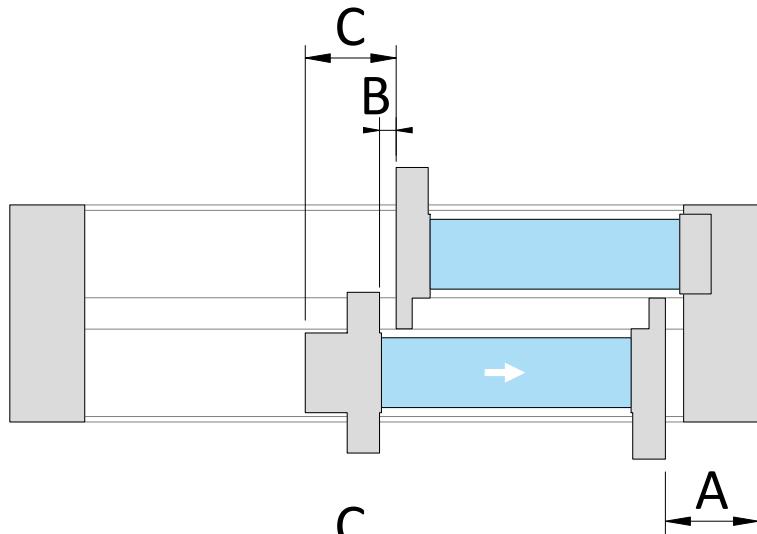

**With LD700**

- A = 100 mm
- B = 20 mm
- C = 88 mm

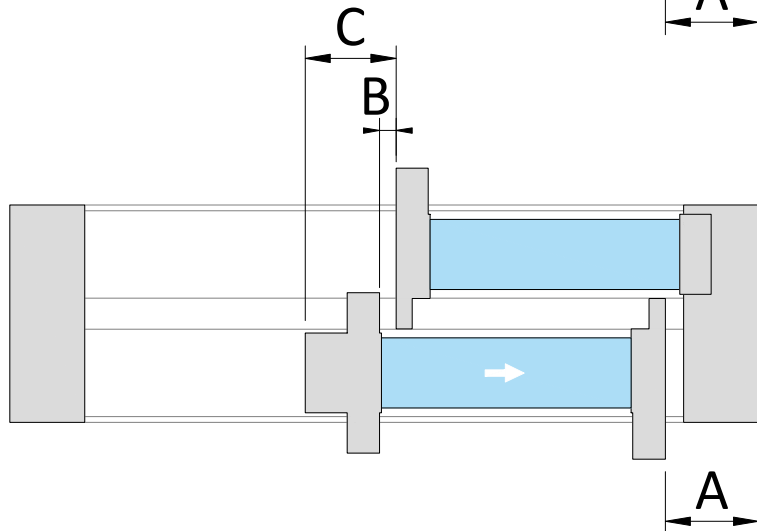

**Housingparts on top of frame**

**LD350**

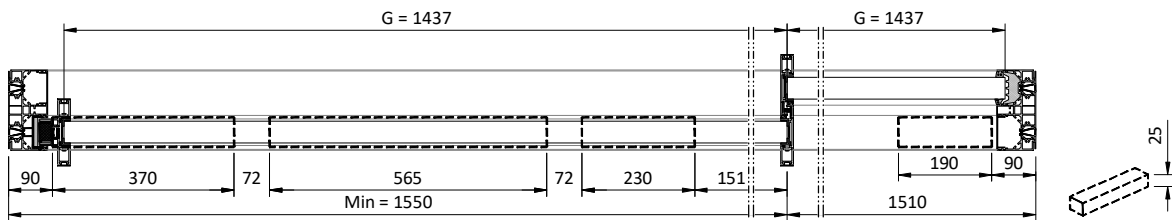

**LD700**

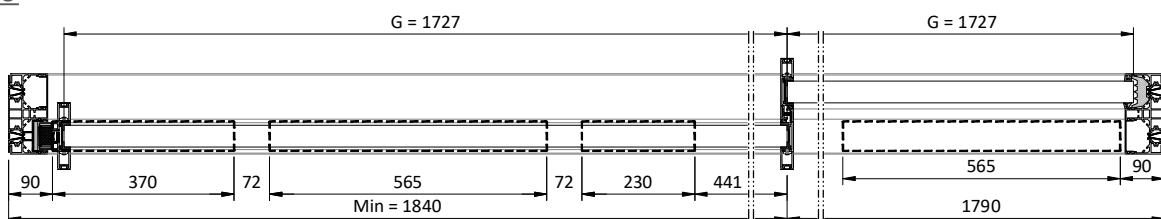

M 1:3

rollo insect screen - closed

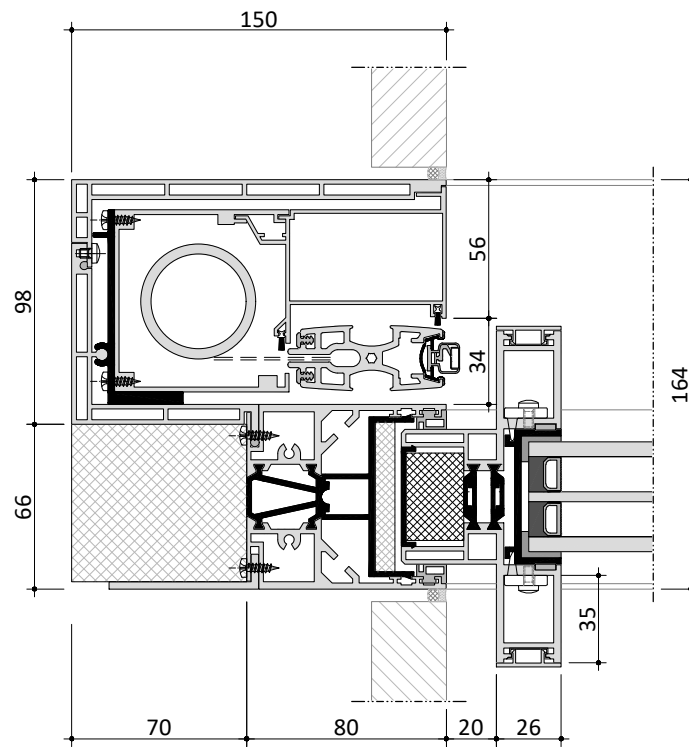
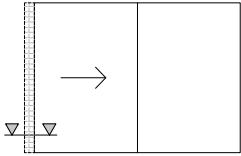

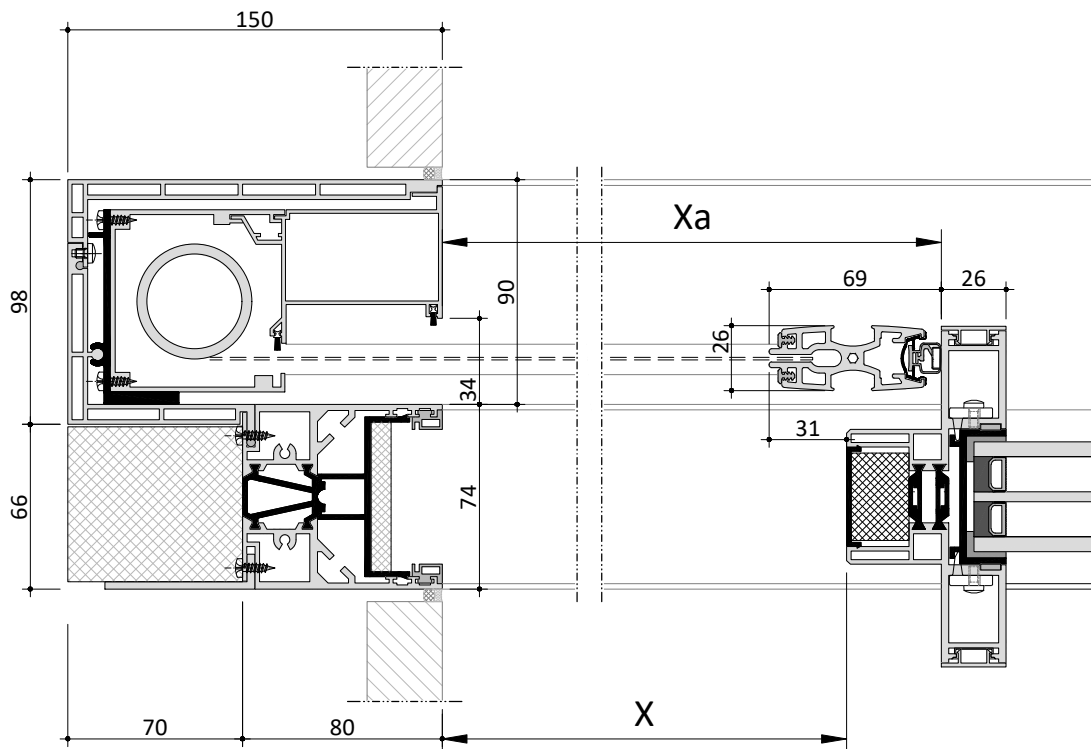
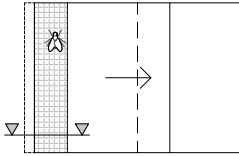

## Measurements

H = 3786 mm -> 4085 mm | X = 915 mm

H = 3286 mm -> 3785 mm | X = 1110 mm

H = 2000 mm -> 3285 mm | X = 1870 mm

Xa = min 700 mm for revision / repair purposes

M 1:3

rollo insect screen

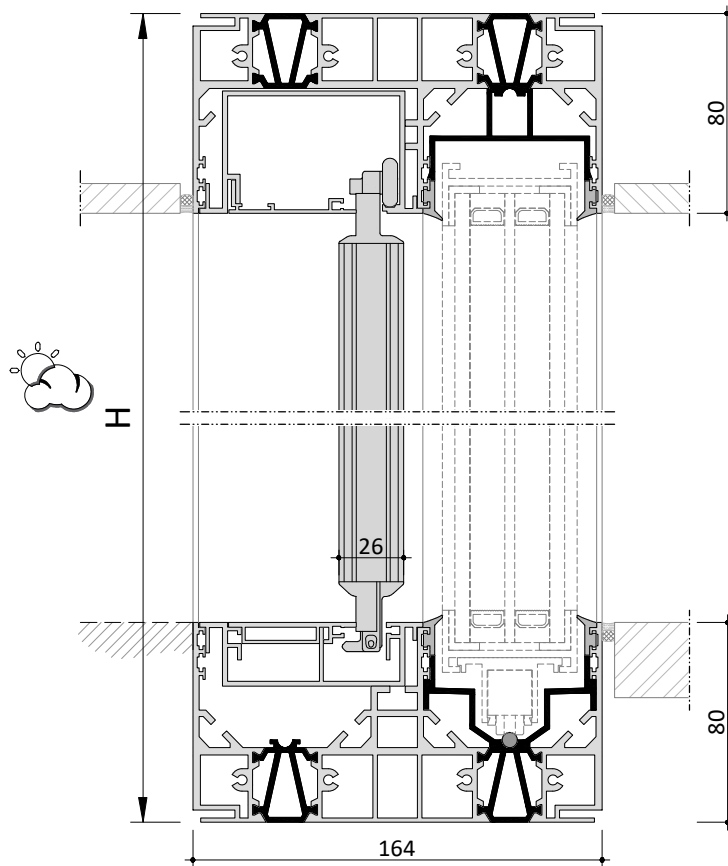
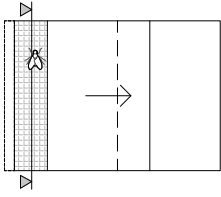

## Measurements

H = 3786 mm -> 4085 mm | X = 915 mm

H = 3286 mm -> 3785 mm | X = 1110 mm

H = 2000 mm -> 3285 mm | X = 1870 mm

M 1:3

rollo insect screen

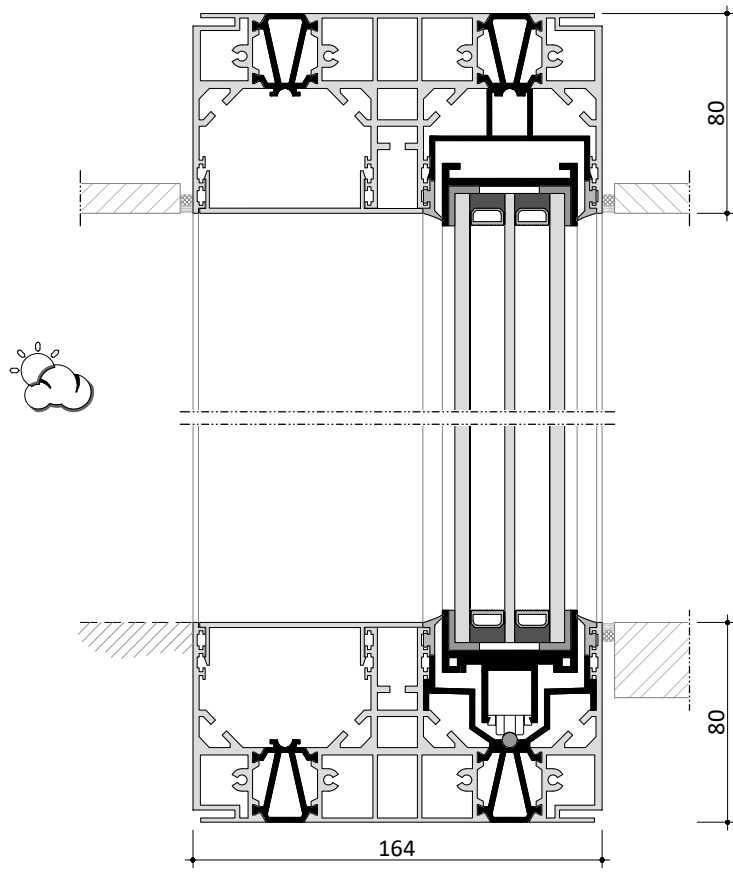
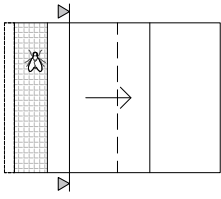

M 1:3

Wall monolithic: sections  
view - side

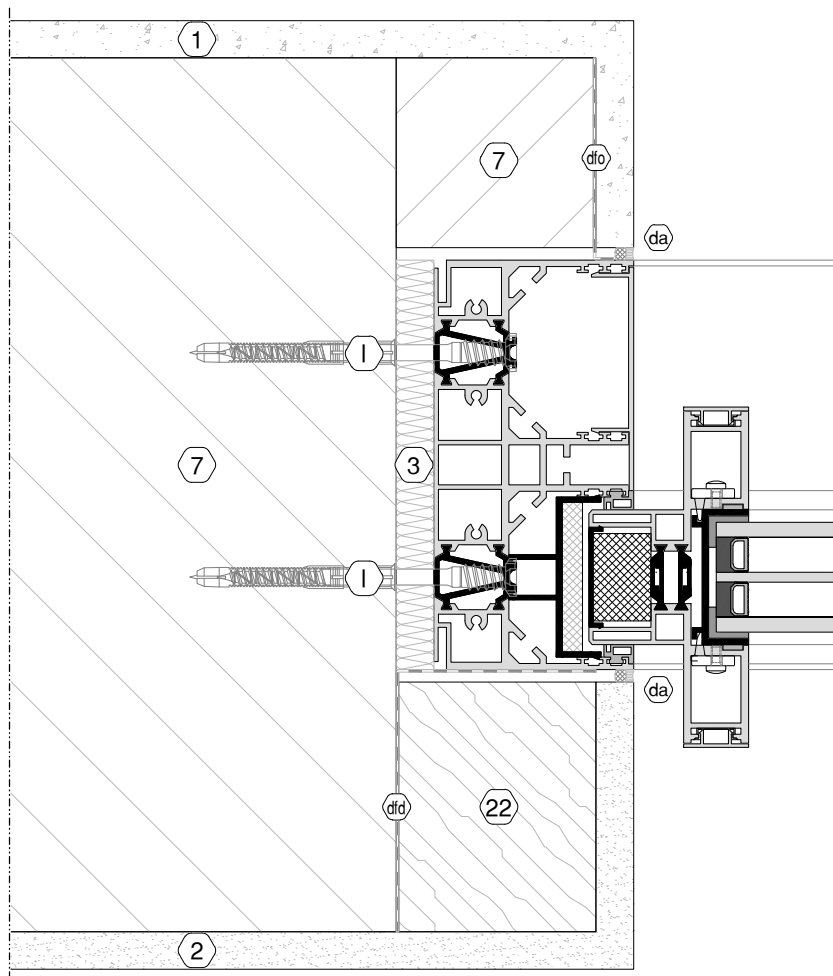
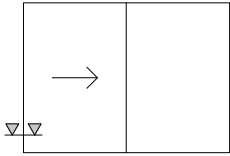

Number legend: see overview at page 07-g



The building connections shown are schematic representations and must be adjusted for the project planning according to the structural conditions and the country-specific requirements.

M 1:3

Wall monolithic: sections  
view - hidden handle

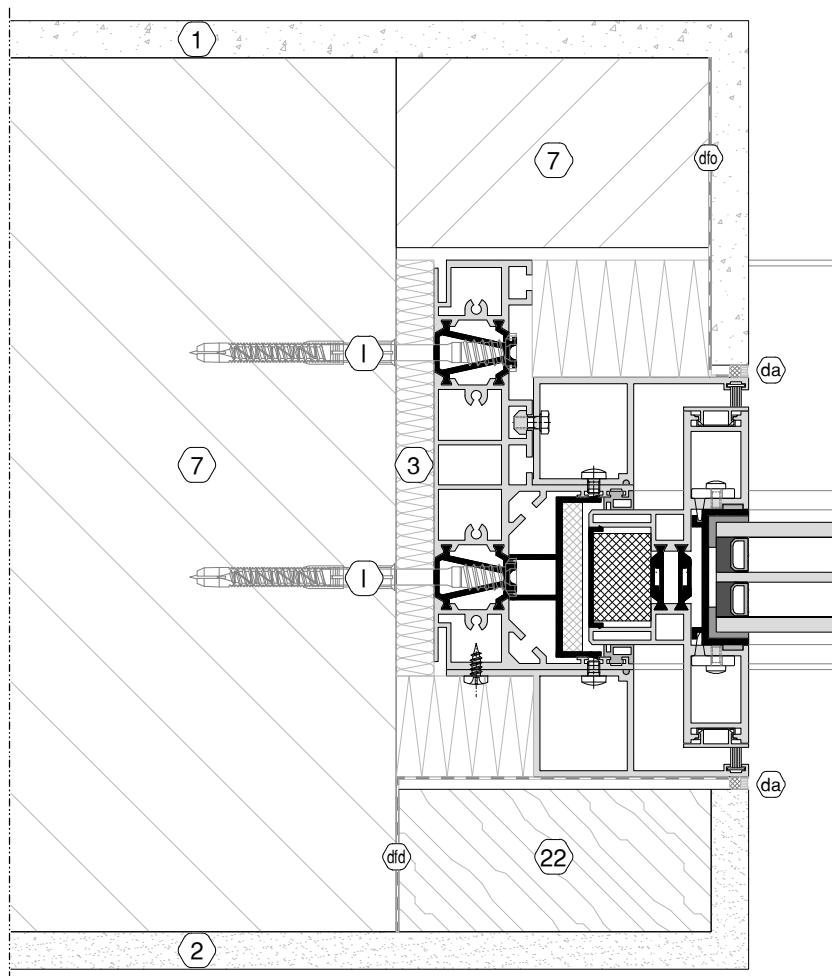
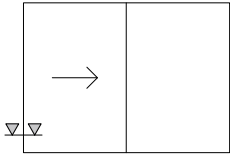

Number legend: see overview at page 07-g



The building connections shown are schematic representations and must be adjusted for the project planning according to the structural conditions and the country-specific requirements.



M 1:3

Wall monolithic: sections  
view - rolo insect screen

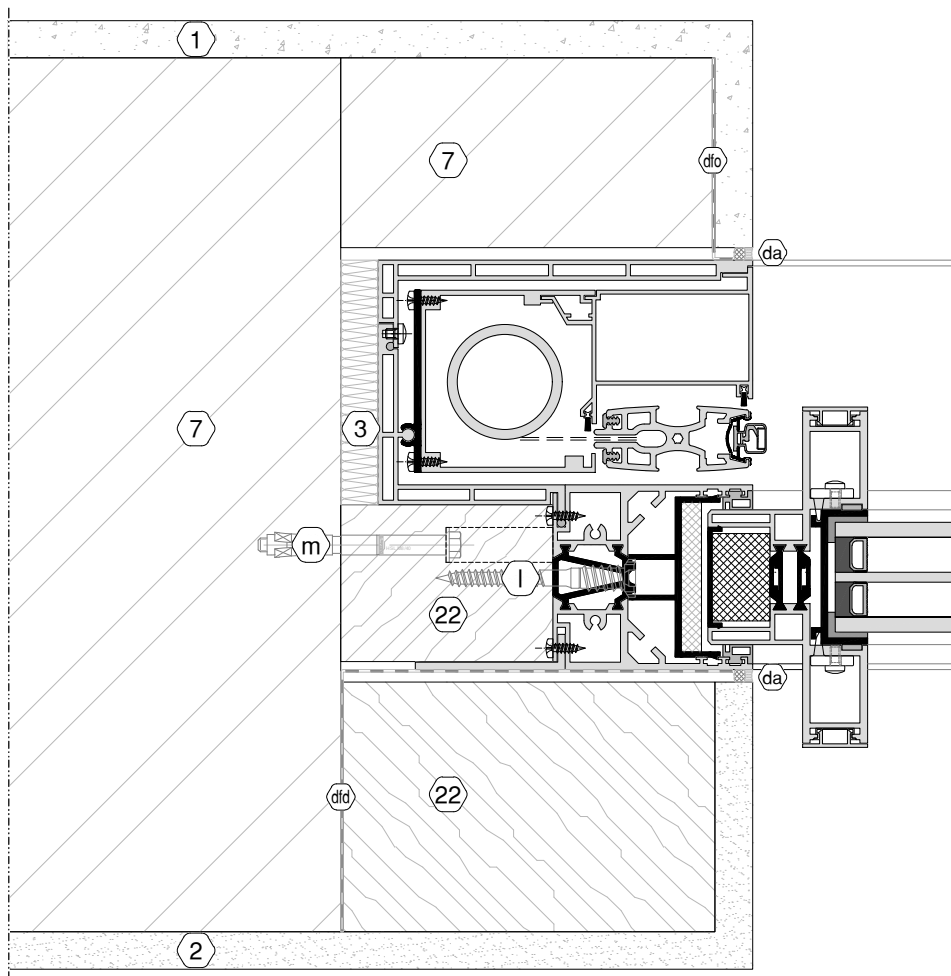
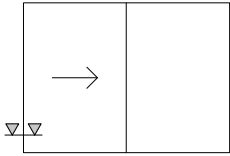

Number legend: see overview at page 07-g



The building connections shown are schematic representations and must be adjusted for the project planning according to the structural conditions and the country-specific requirements.

M 1:3

Wall monolithic: sections  
view - top

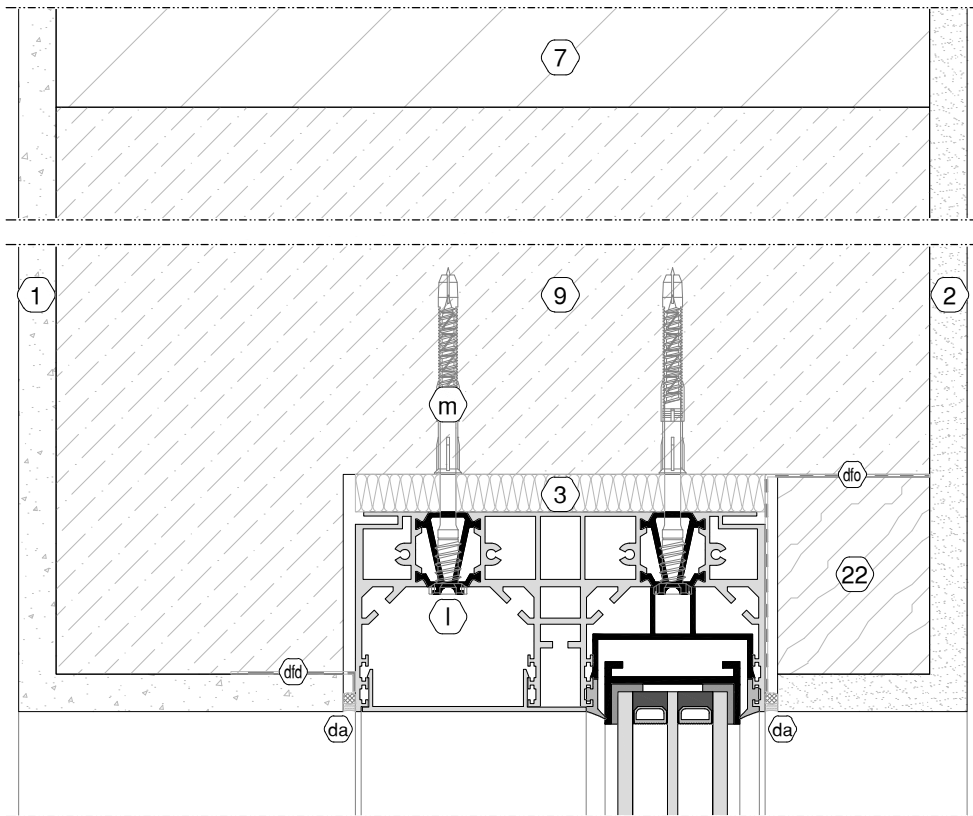
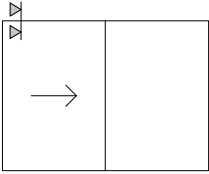

Number legend: see overview at page 07-g



The building connections shown are schematic representations and must be adjusted for the project planning according to the structural conditions and the country-specific requirements.

M 1:3

Wall monolithic: sections  
view sliding & visible gutter

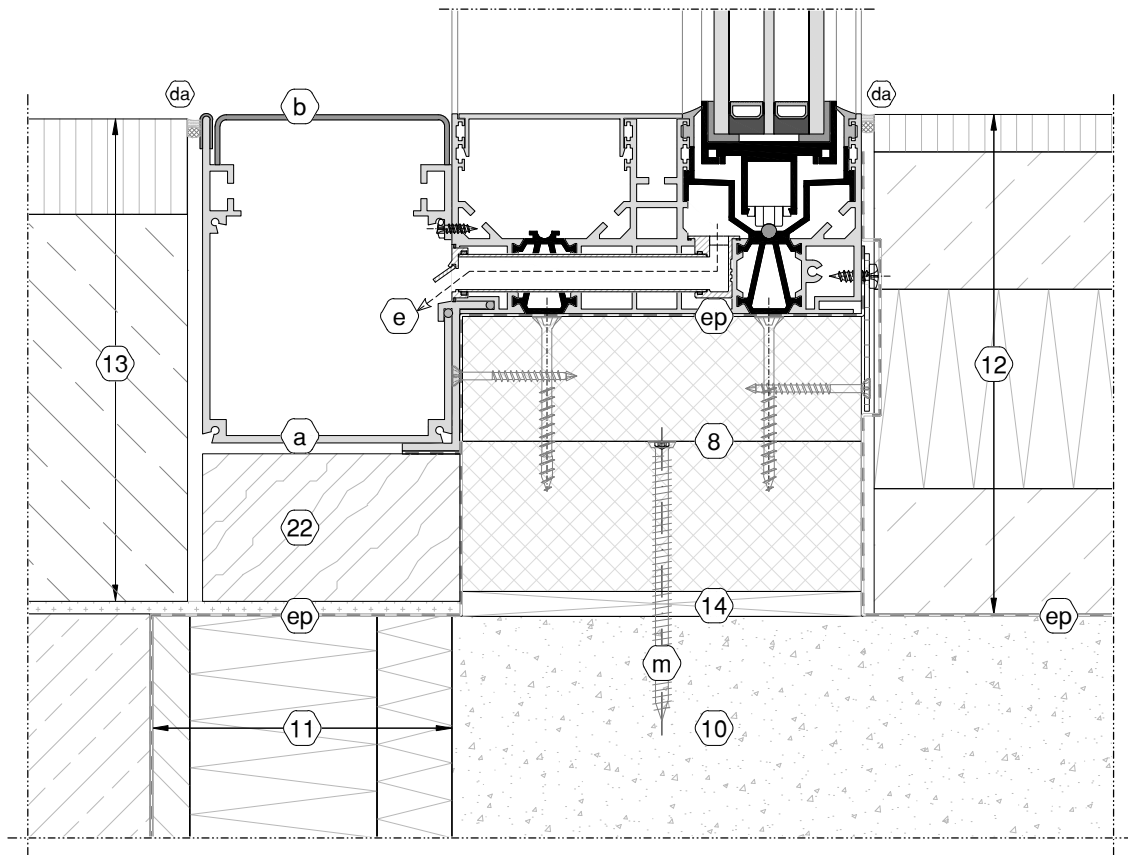
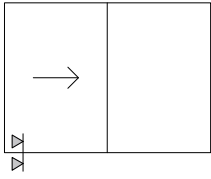

Number legend: see overview at page 07-g



The building connections shown are schematic representations and must be adjusted for the project planning according to the structural conditions and the country-specific requirements.

M 1:3

Wall monolithic: sections  
view fix & visible gutter

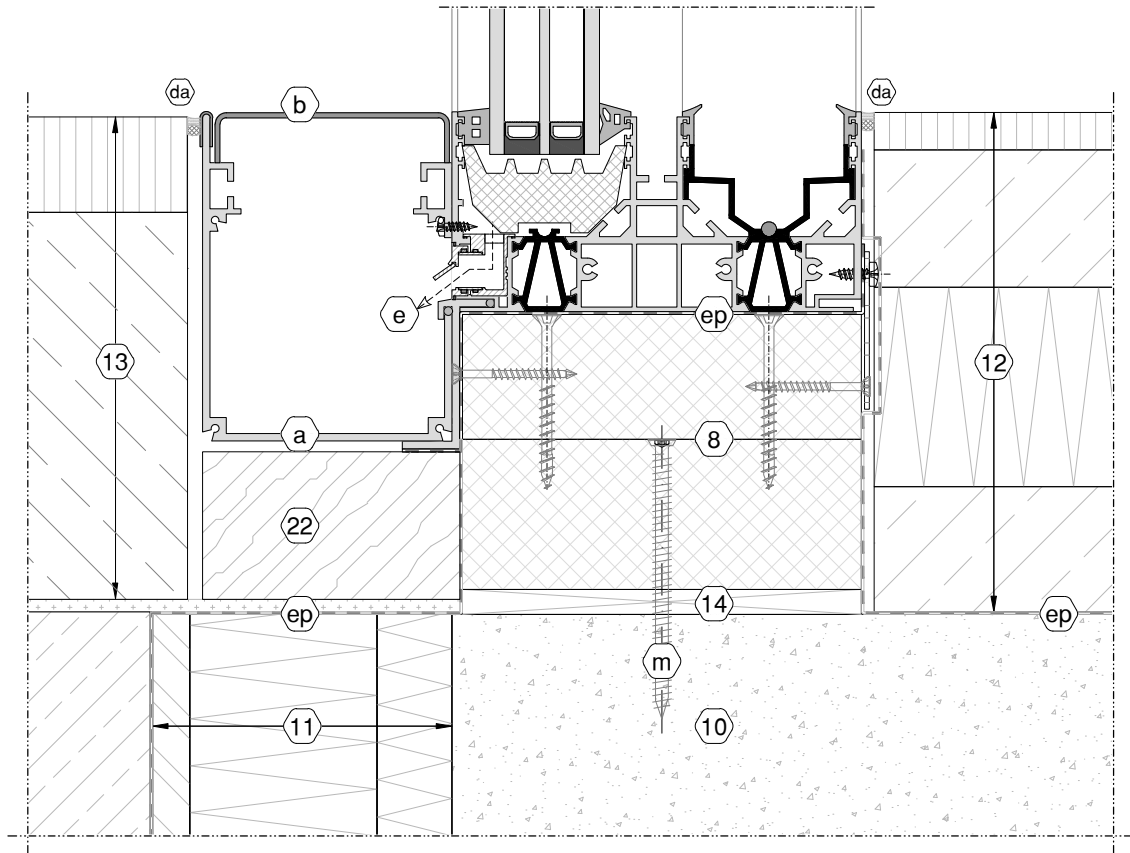
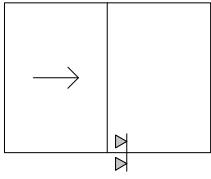

Number legend: see overview at page 07-g



The building connections shown are schematic representations and must be adjusted for the project planning according to the structural conditions and the country-specific requirements.

M 1:3

Wall monolithic: sections  
view sliding & invisible gutter

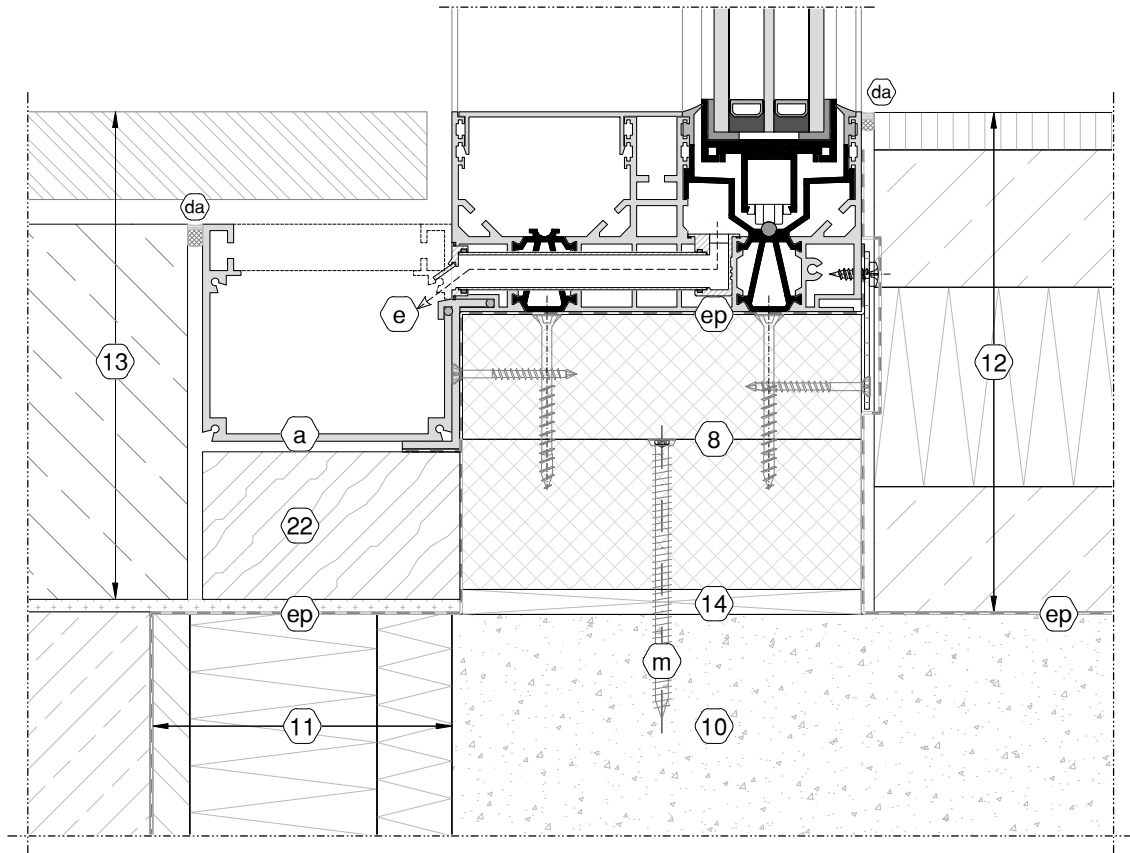
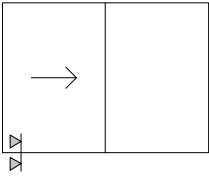

Number legend: see overview at page 07-g



The building connections shown are schematic representations and must be adjusted for the project planning according to the structural conditions and the country-specific requirements.

M 1:3

Wall monolithic: sections  
view fix & invisible gutter

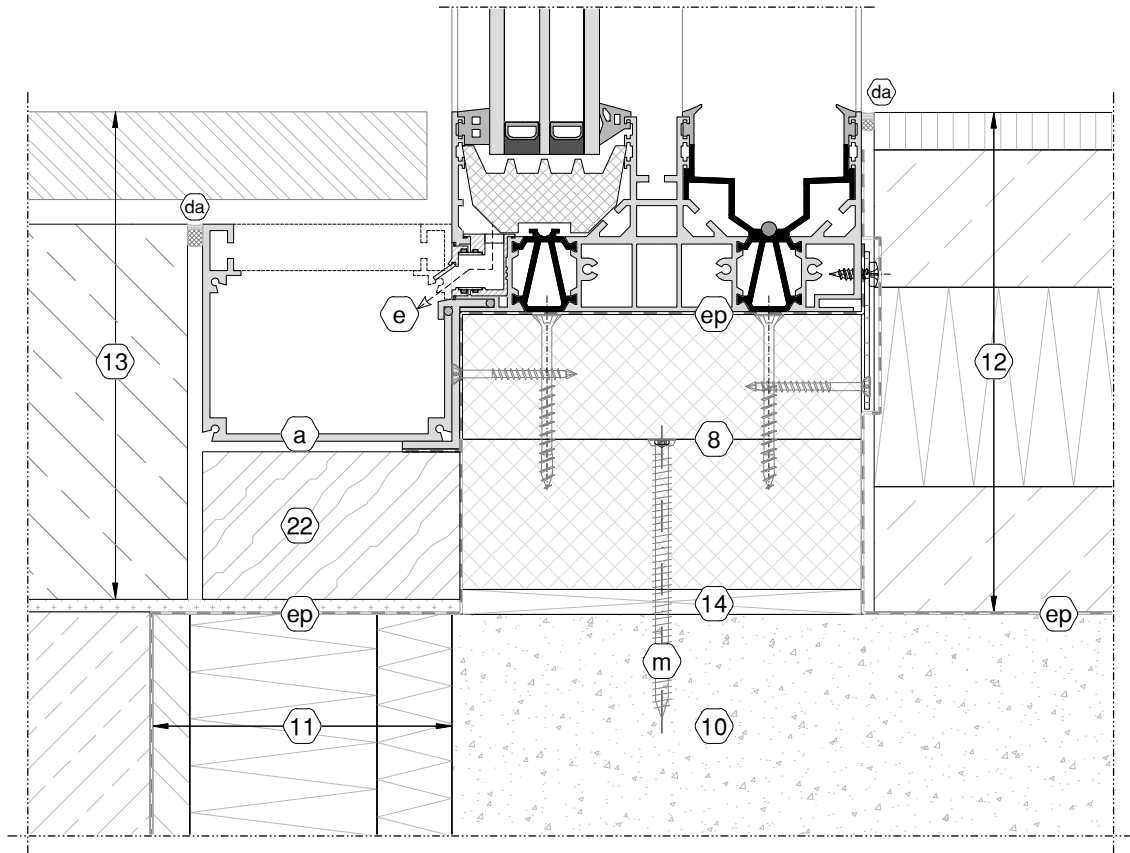
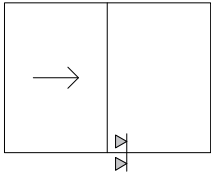

Number legend: see overview at page 07-g



The building connections shown are schematic representations and must be adjusted for the project planning according to the structural conditions and the country-specific requirements.

M 1:3

Wall monolithic: sections  
view - Suisse solution

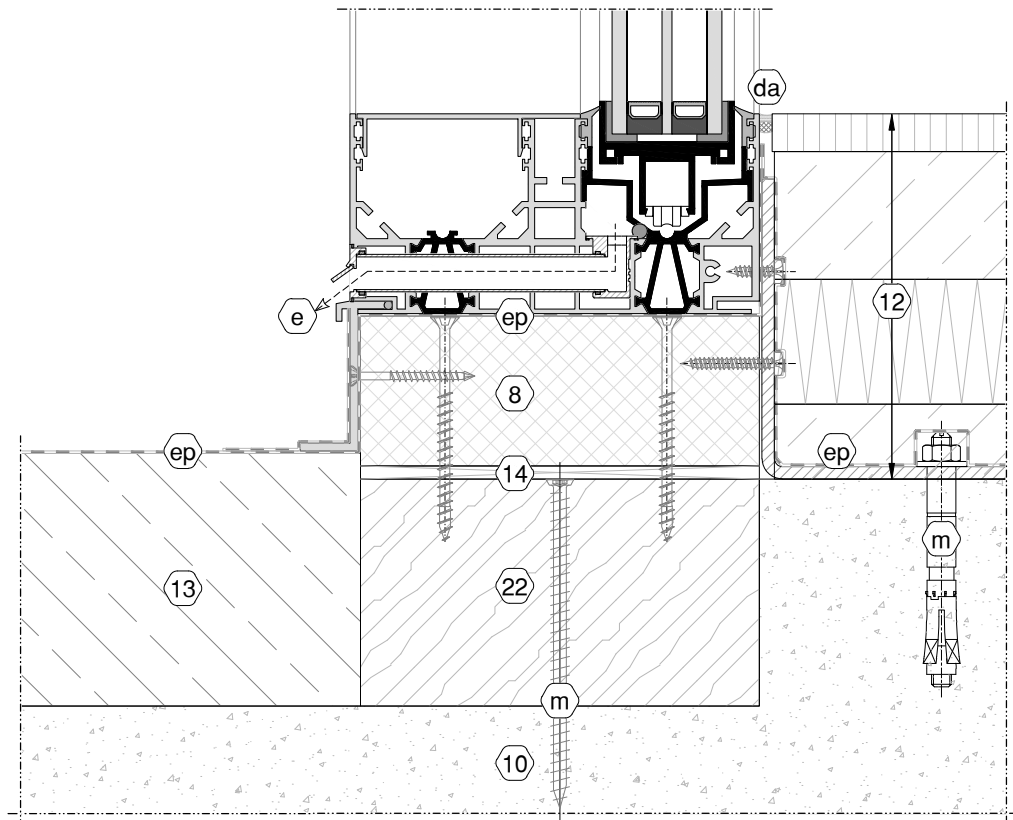
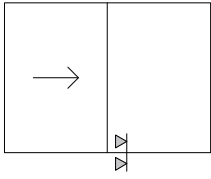

Number legend: see overview at page 07-g



The building connections shown are schematic representations and must be adjusted for the project planning according to the structural conditions and the country-specific requirements.



M 1:3

Wall monolithic: sections  
view & alu threshold

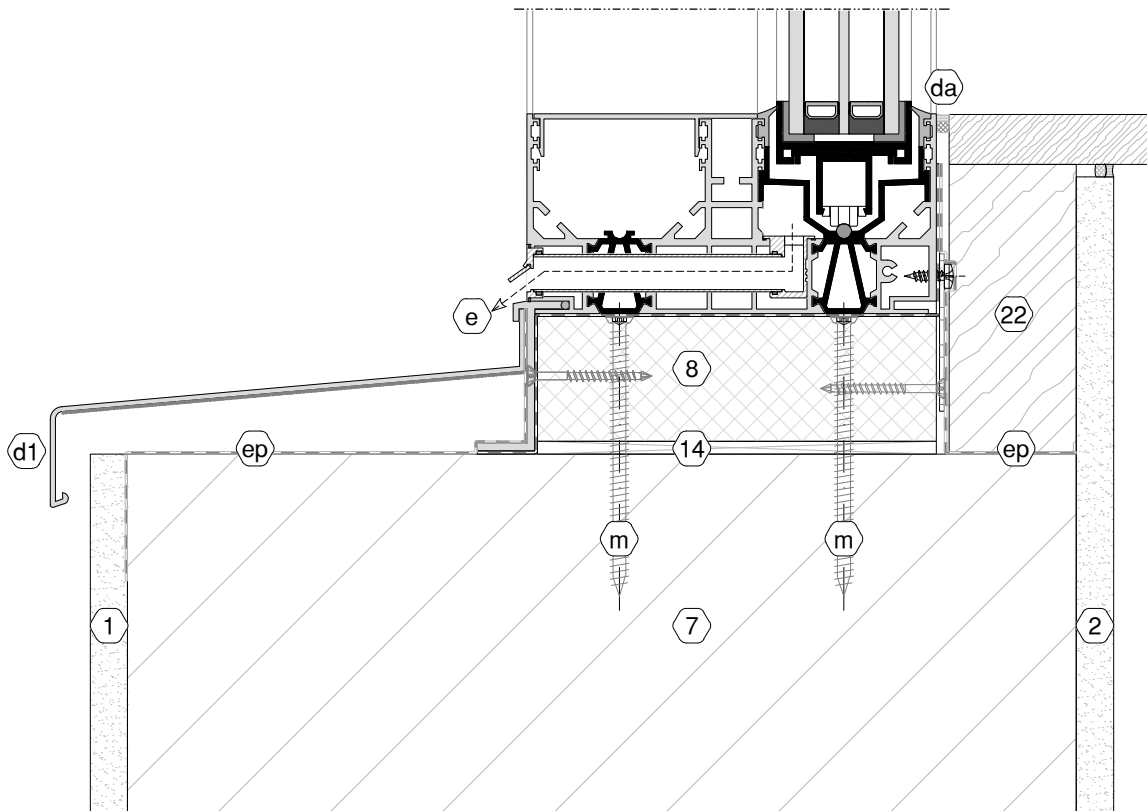
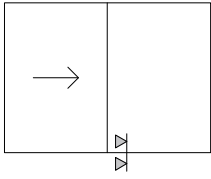

Number legend: see overview at page 07-g



The building connections shown are schematic representations and must be adjusted for the project planning according to the structural conditions and the country-specific requirements.

M 1:3

Wall monolithic: sections  
floor PL sliding & invisible gutter

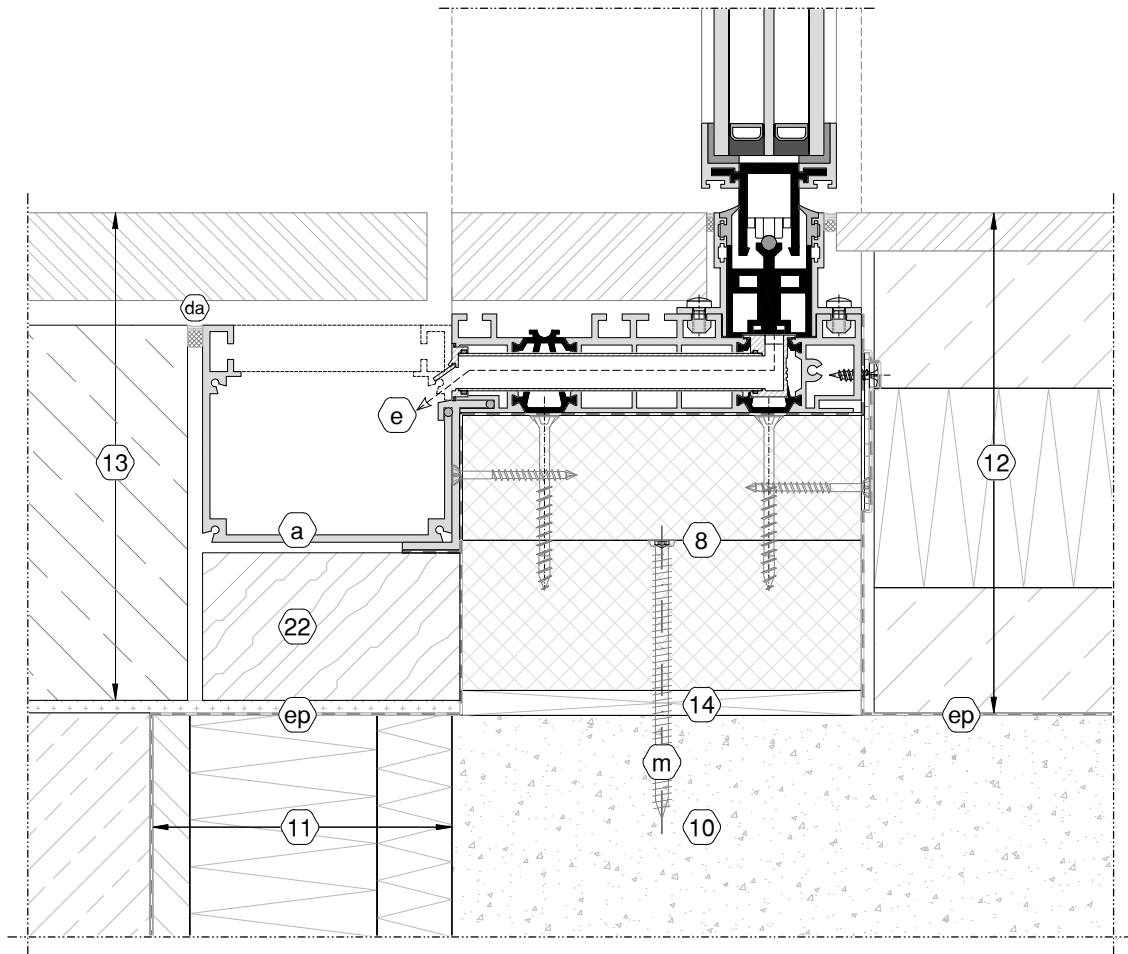
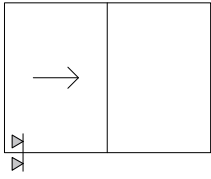

Number legend: see overview at page 07-g



The building connections shown are schematic representations and must be adjusted for the project planning according to the structural conditions and the country-specific requirements.

M 1:3

Wall monolithic: sections  
floor CL sliding & invisible gutter

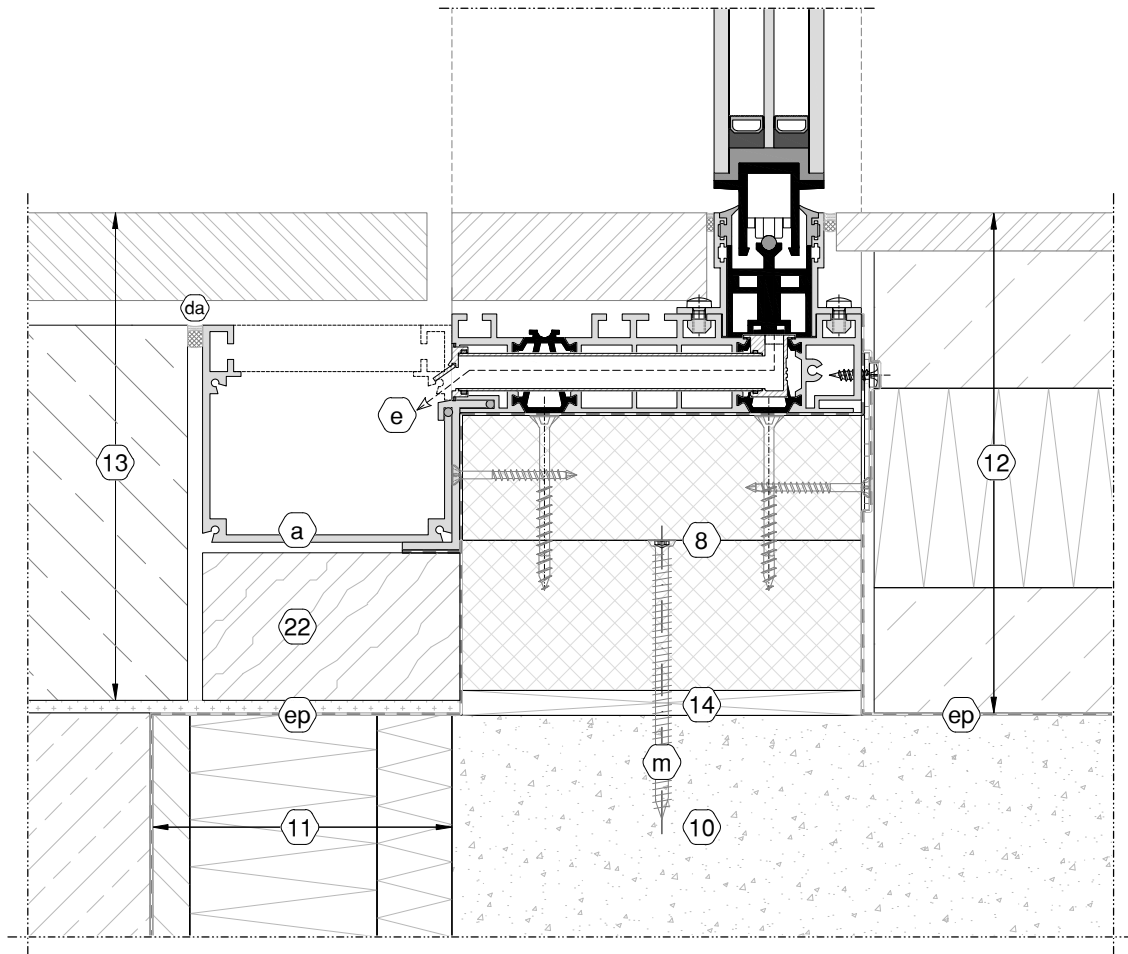
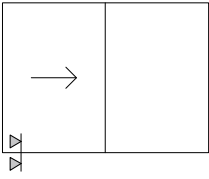

Number legend: see overview at page 07-g



The building connections shown are schematic representations and must be adjusted for the project planning according to the structural conditions and the country-specific requirements.

M 1:3

Wall monolithic: sections  
floor PL/CL fix & invisible gutter

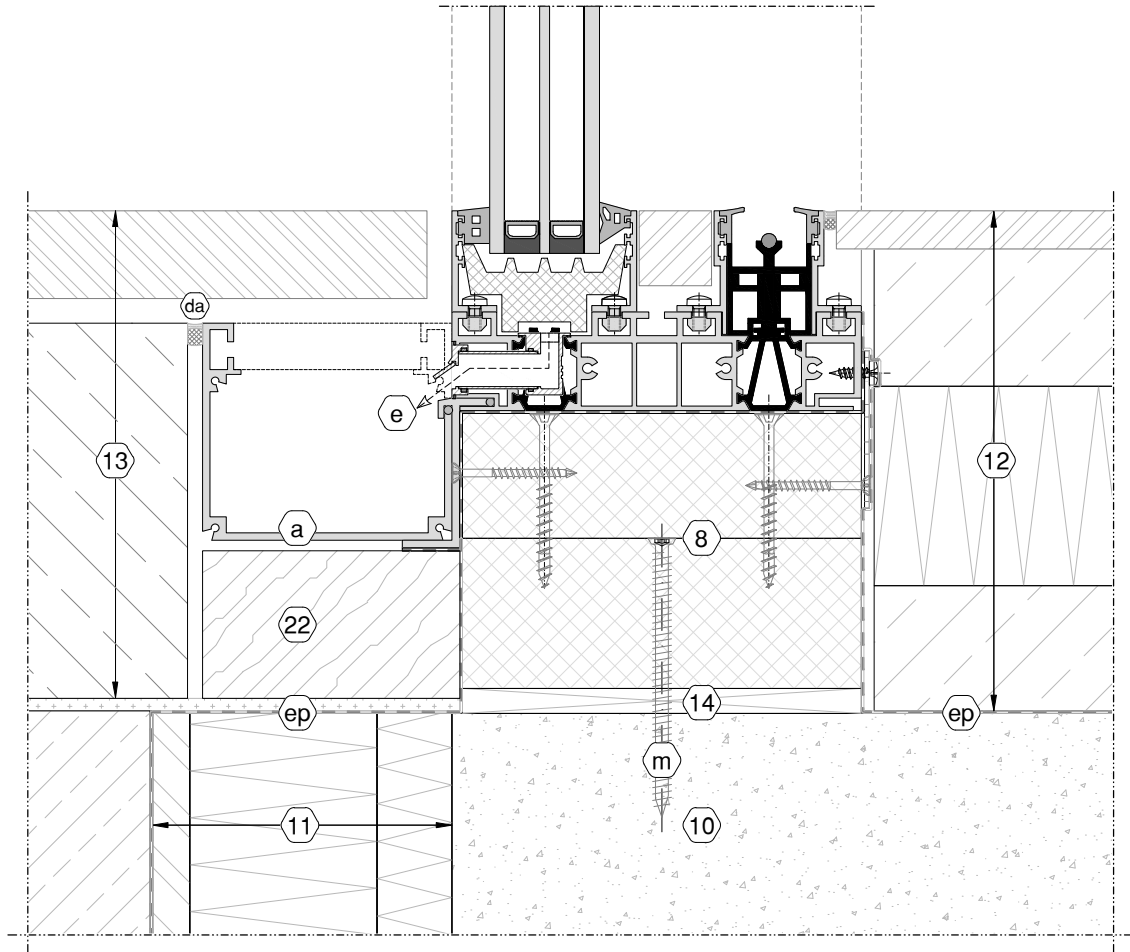
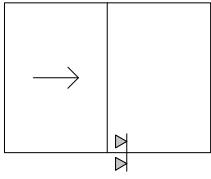

Number legend: see overview at page 07-g



The building connections shown are schematic representations and must be adjusted for the project planning according to the structural conditions and the country-specific requirements.

1	Exterior plaster
2	Interior plaster
3	Thermal insulation
4	Flexifoam
5	Exterior wall (façade)
6	Interior brickwork
7	Thermal insulation bricks
8	KELLER base stone
9	Concrete lintel
10	Concrete plate
11	Concrete plate edge
12	Floor structure
13	Terrace structure
14	Pressure resistant (plastic) underlay
15	Steel/alu angle profile (with reinforcement)
16	Insulating blocks
17	DWD board
18	OSB board
19	Wooden wall structure
20	Gypsum fiberboard
21	Installation level
22	Filling in general
23	Venetian blinds / roller blinds
24	Ventilated facade system
25	Floor strip
26	Blind drainage slot
a	Drainage gutter [AlMgSi0.5]
b	Gutter cover [stainless steel]
c	Edge protection [stainless steel]
d1	Windowsill system: standard
e	Drainage
f	Drainage base [PVC-U]
g	Substructure [KELLER base stone]
h	PET
i	EPDM cellular rubber
k	Fixing bushing
l	Topstar
m	Anchor / wall screw
n	Zebra Pias AW30
da	Permanently elastic sealing
dfo	Vapour diffusion-permeable film
dfd	Vapour diffusion-tight film
de	Sealing foil EPDM



The connections shown are schematic representations and must be adjusted for the project planning according to the structural conditions on site and the country-specific requirements.

All information contained in this manual has been compiled to the best of our knowledge and tested with care. Nevertheless, errors cannot be completely ruled out. For this reason, the information contained in these instructions is not associated with any obligation or guarantee of any kind. As a result, Keller minimal windows S.A. accepts no responsibility and will not accept any consequential or other liability arising in any way from the use of this information - or any part thereof - including for any infringement of patent rights which may result.

Likewise, Keller minimal windows S.A. does not guarantee that the processes described are free from the property rights of third parties. The reproduction of common names, trade names, product descriptions, etc. in this work does not justify the assumption that such names are to be considered free in the sense of trademark and brand protection legislation and may therefore be used by anyone, even without special labelling.

The contents and data contained in this work are protected by copyright. All rights to the contents are the sole property of Keller minimal windows S.A..

Any transfer to third parties and any further use or exploitation of the contents outside the legal limits - in particular those of the copyright law - is not permitted without the prior written consent of Keller minimal windows S.A..

Luxembourg law applies.

Copyright © 2021 Keller Minimal Windows S.A.

Responsible publisher

**Keller Minimal Windows S.A.**  
38-40, Route de Wilwerdange  
L-9911 Troisvierges  
Tel. +352 28 38 66 01  
info@keller-minimal-windows.com  
www.minimal-windows.com







ALUMINIUM CRÉATIONS SA  
Rue du Châtelard 18  
CH 1400 Yverdon-les-Bains  
T : +41 (0) 58 206 0 206  
F : +41 (0) 58 206 0 200  
[www.alucreations.ch](http://www.alucreations.ch)

VÉRANDAS

BAIES VITRÉES  
& FENÊTRES

PERGOLAS

STORES

CONSTRUCTIONS  
MÉTALLIQUES

NG S4

NG S5

NG S6

NG S7

## minimal windows® NG S6

01

- a technical data sheet NG S6

## Technical sections

02

- a outer frame
- b sasch frame "view" & "floor"
- c handle bar- double vent profiles
- d junction profiles
- e locking
- f highline type 3
- g further development (\*)

## Elements

03

- a 1x fix 1R & 2x fix highline
- b SF
- c SS
- d FSSF (2R) (double vent)
- e SSSS (2R) (double vent)
- f SSF (3R)
- g SSS (3R)
- h other possibilities (\*)

## Electronics

04

- a selection criterion table  
LD350 & LD700
- b smart slider - lateral drive
- c smart slider - top drive
- d soft open-close (\*)
- e opening monitoring (\*)
- f closure monitoring (\*)

## Accessories

05

- a rollo insect screen
- b other possibilities (\*)

## Test reports

06

- a (\*)

## Building connections

07

- a wall monolithic
- b other possibilities (\*)

## Impressum

08

- a legal information

(\*) in progress





## System

Facing width	: 26 mm	Max. leaf area fix	: 18 m <sup>2</sup>
Installation flush to the floor	: possible	Max. numbers of tracks	: up to 3 tracks
Installation flush to the ceiling	: possible	Overall insulation glass thickness	: 54 up to 64 mm
Max. leaf height	: 6 m	Automated sliding leaf	: yes
Min. B/H	: 1/3	Motorisation (*)	: up to 2400 kg
Max. leaf weight	: 1500 kg	(*) total weight with one motor and combined leaves	
Max. leaf area sliding	: 18 m <sup>2</sup>	Accessibility	: DIN 18040-1, DIN 18040-2

## Building physics

U <sub>w</sub> -Values (dep. on glass type & dimensions)	: ≥0,9 W/(m <sup>2</sup> K) (a)   ≥0,65 W/(m <sup>2</sup> K) (b)
Air permeability	: up to classe 4 → EN 12207 (c)
Resistance to rain penetration	: up to classe 8A → EN 12208 (d)
Resistance to wind loads	: up to classe C5 → EN 12210 (c)
Sound insulation	: up to 46 dB → ISO 717-1 (c)

## Safety

Resistance to burglary	: up to RC 3 → EN 1627 (c) & PAS24
------------------------	------------------------------------

- (a) Theoretical R&D calculation for sliding-fixe 6.0 x 6.0 m with glass Ug 0.8 W/m<sup>2</sup>K
- (b) Theoretical R&D calculation for sliding-fixe 6.0 x 6.0 m with glass Ug 0.5 W/m<sup>2</sup>K
- (c) Target value, waiting for official testing
- (d) Target value for drainage type 1 (target value for drainage type 2 & 3 >8A)

## Mounting directions

Max. allowable bending of outer frame	: During assembly
	a : ± 0.5mm / m
	b : ± 1mm
	: During operation
	a : ± 1mm / m
	b : + 2 / - 5mm

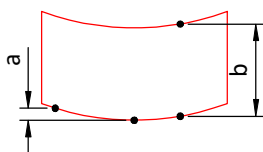

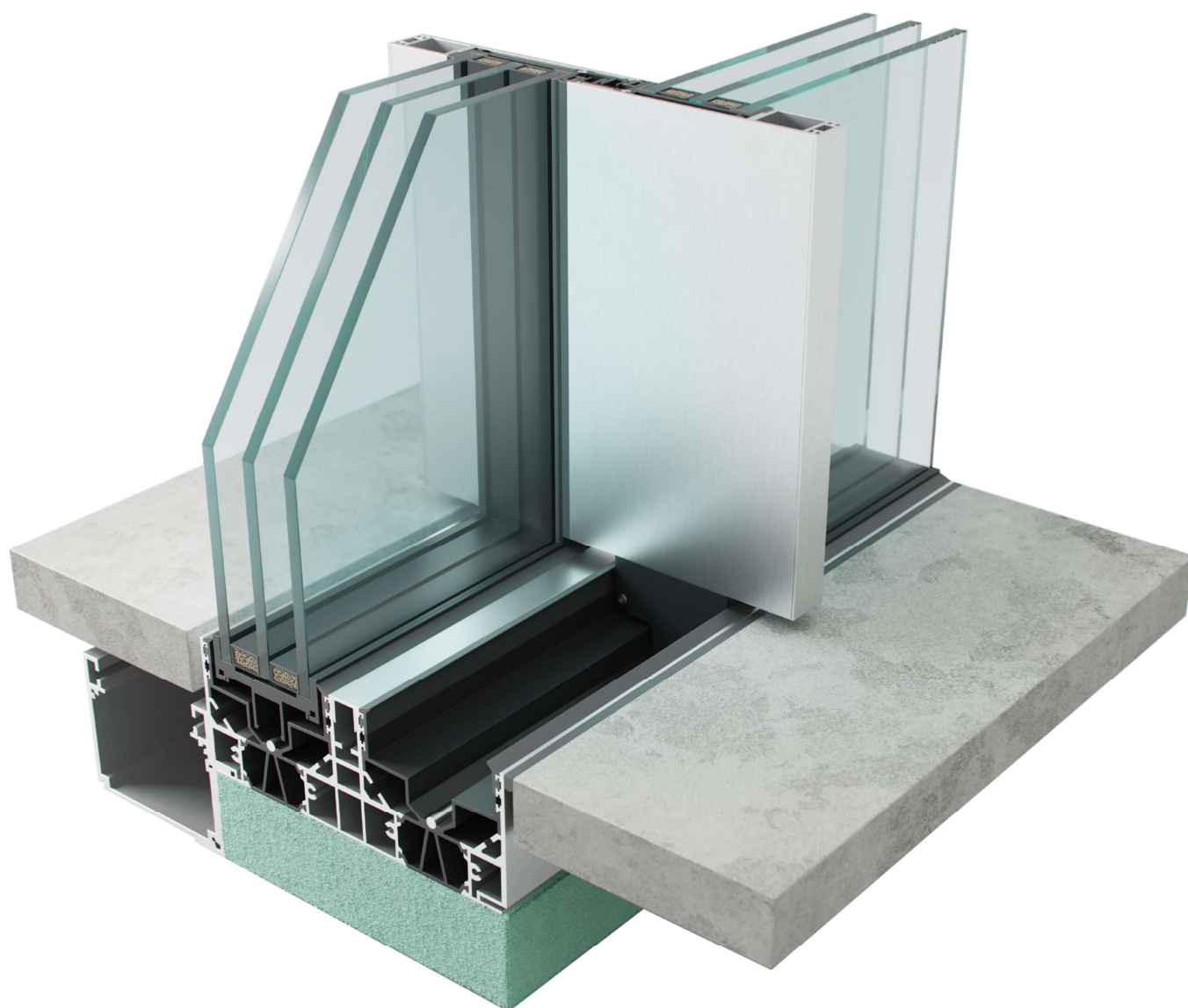

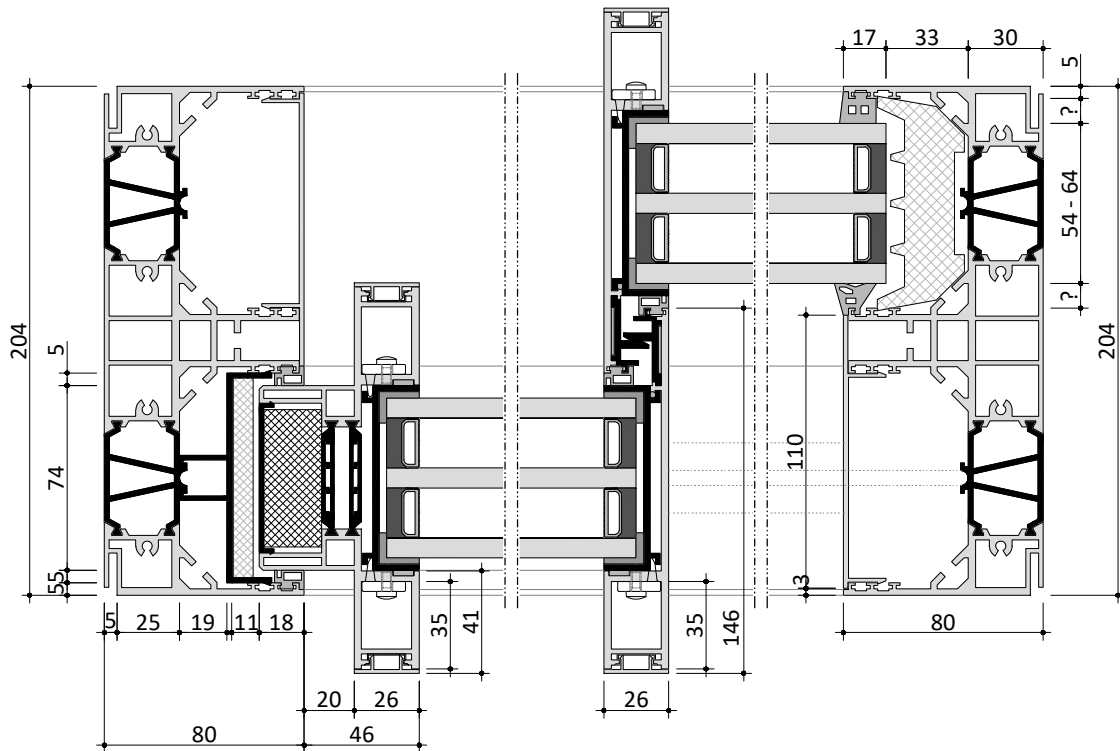
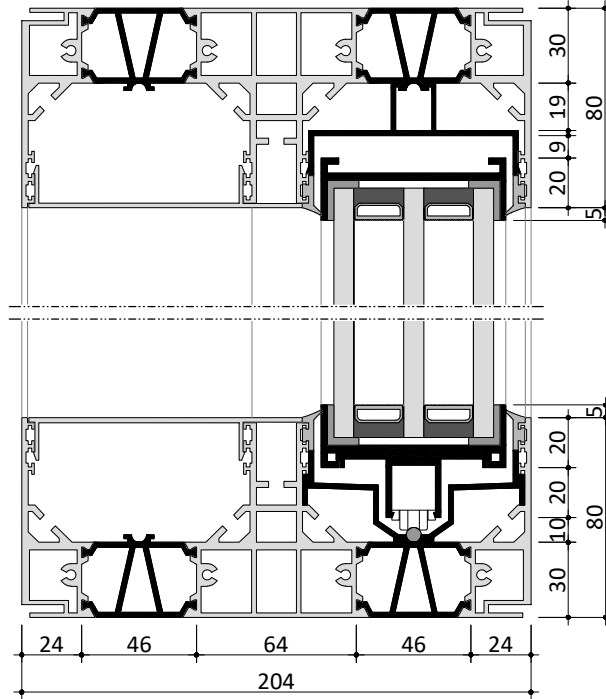
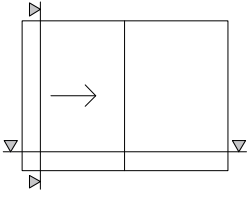

M 1:3 outer frames : view - floor PL - floor CL

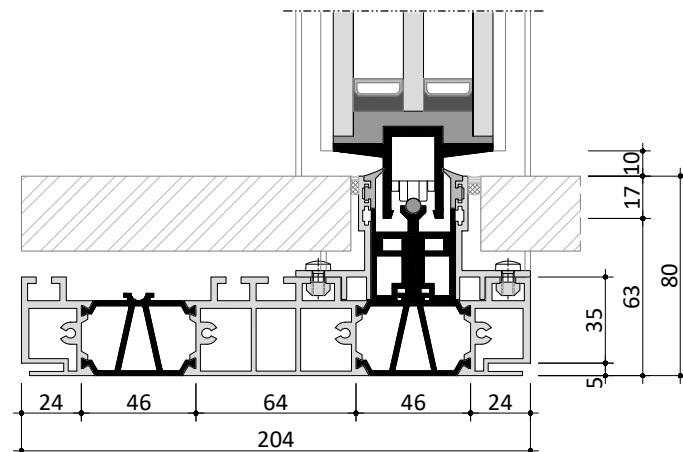
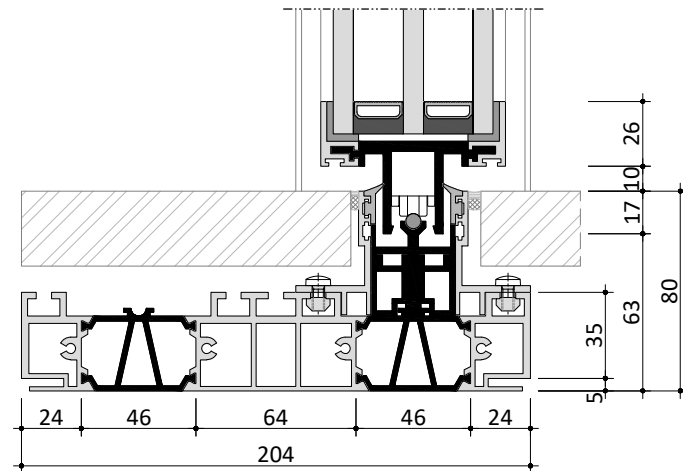
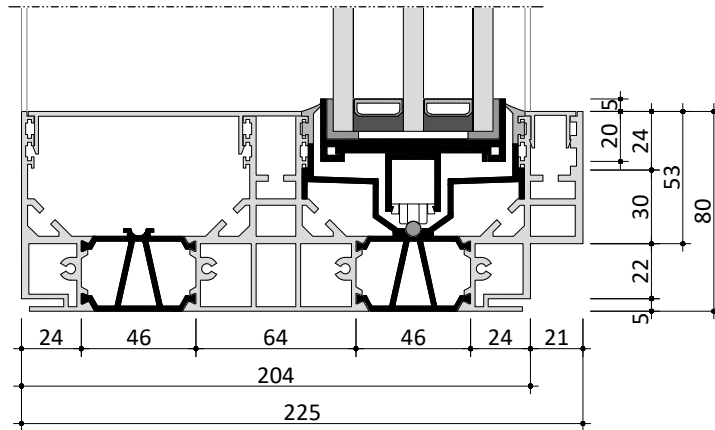
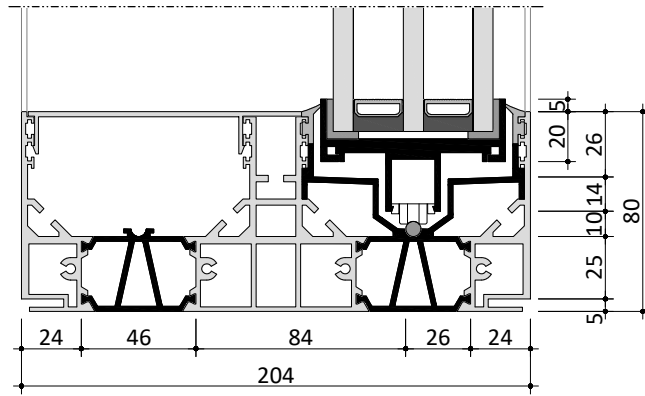
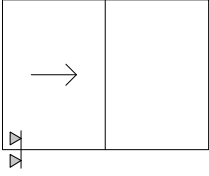

# Technical sections

02-a2

M 1:3

outer frames

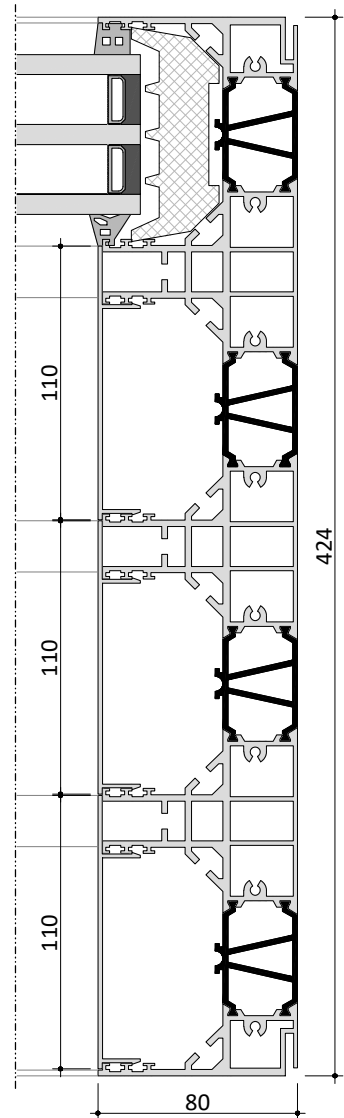
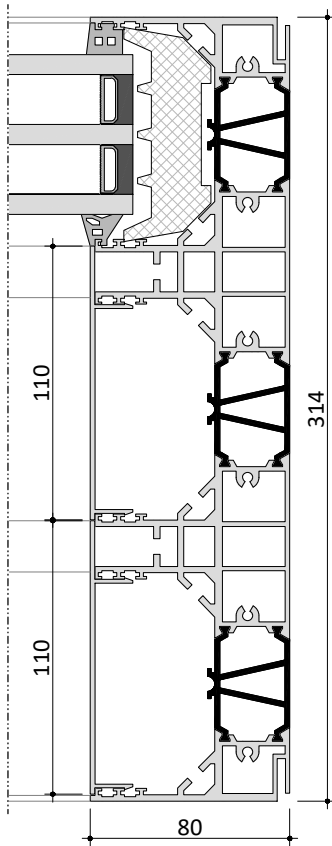
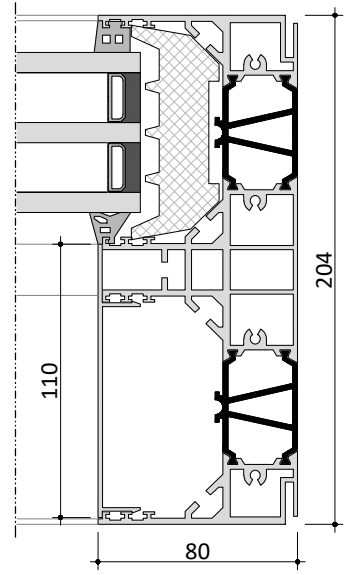
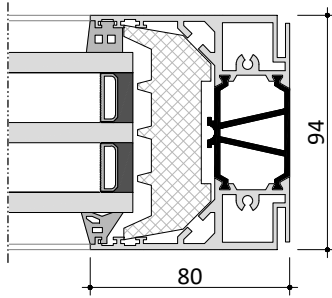
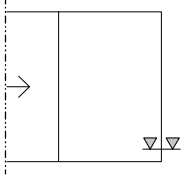

M 1:3

outer frames : Z-schell separator

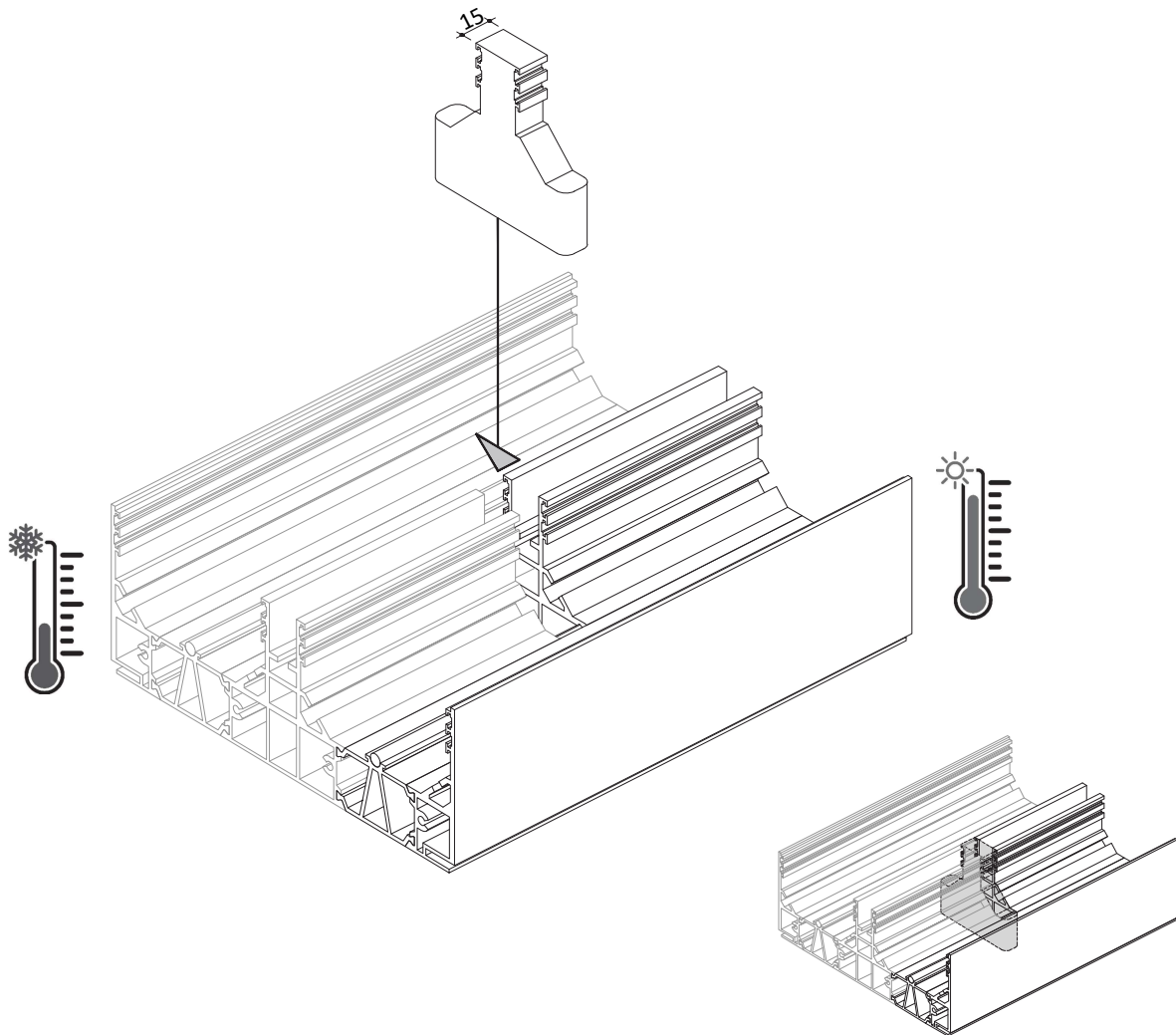
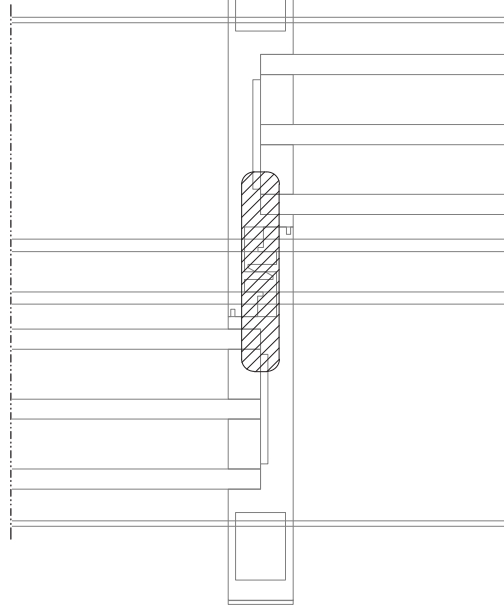
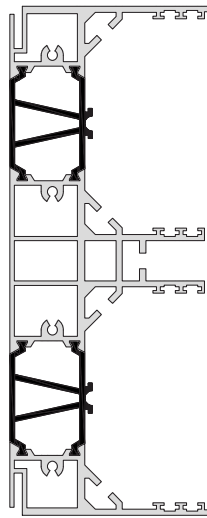
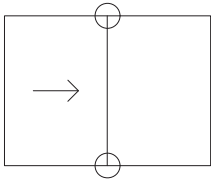

M 1:3

view - sliding

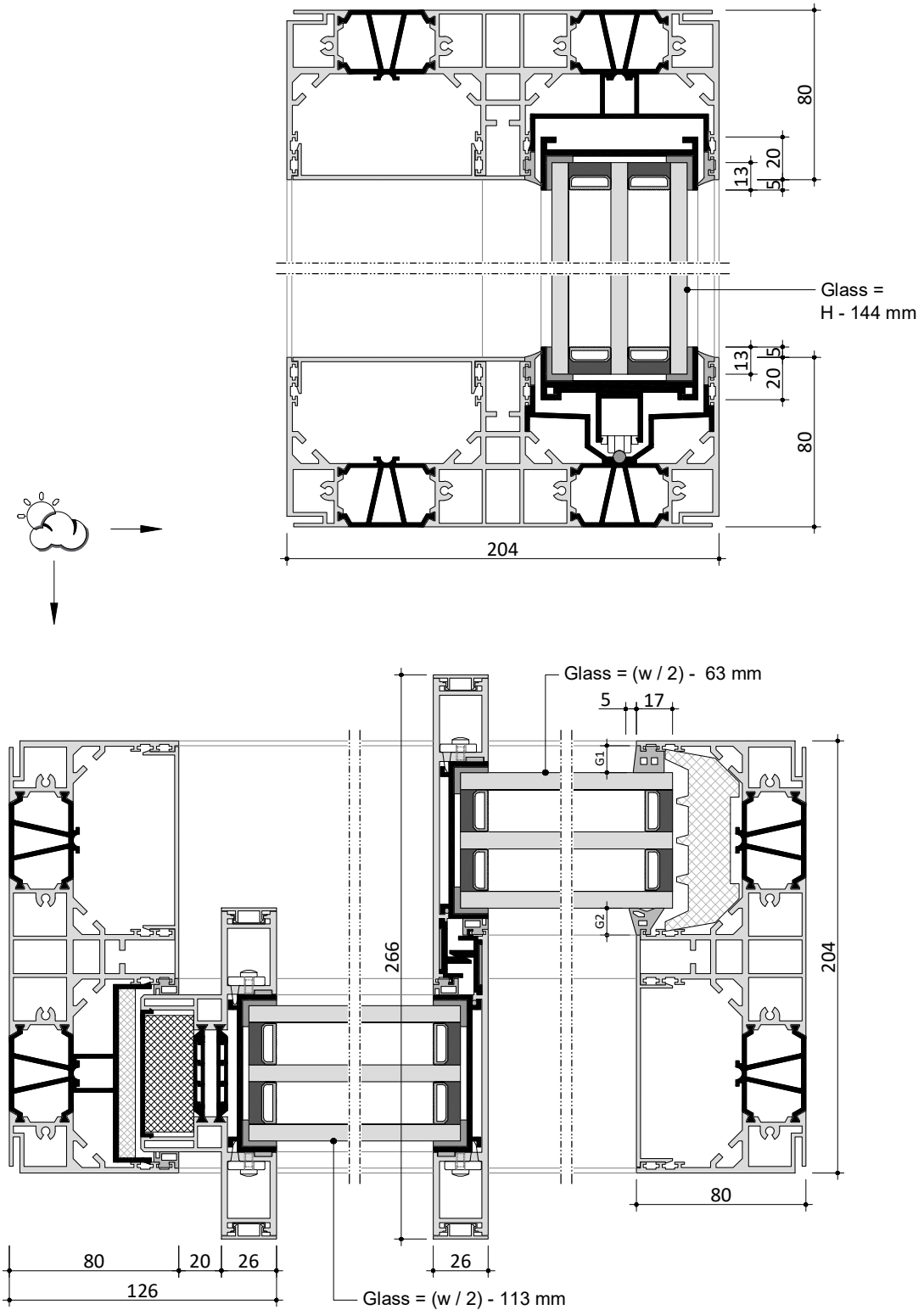
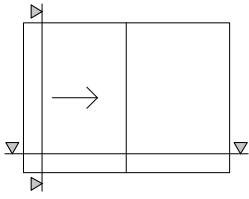



M 1:3

view - fix

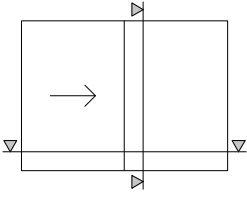

	G1	G2
	G1	G2
54mm	15 mm	15 mm
55mm	14 mm	15 mm
56mm	14 mm	15 mm
57mm	13 mm	15 mm
58mm	13 mm	13 mm
59mm	12 mm	13 mm
60mm	12 mm	13 mm
61mm	11 mm	13 mm
62mm	11 mm	11 mm
63mm	10 mm	11 mm
64mm	10 mm	11 mm

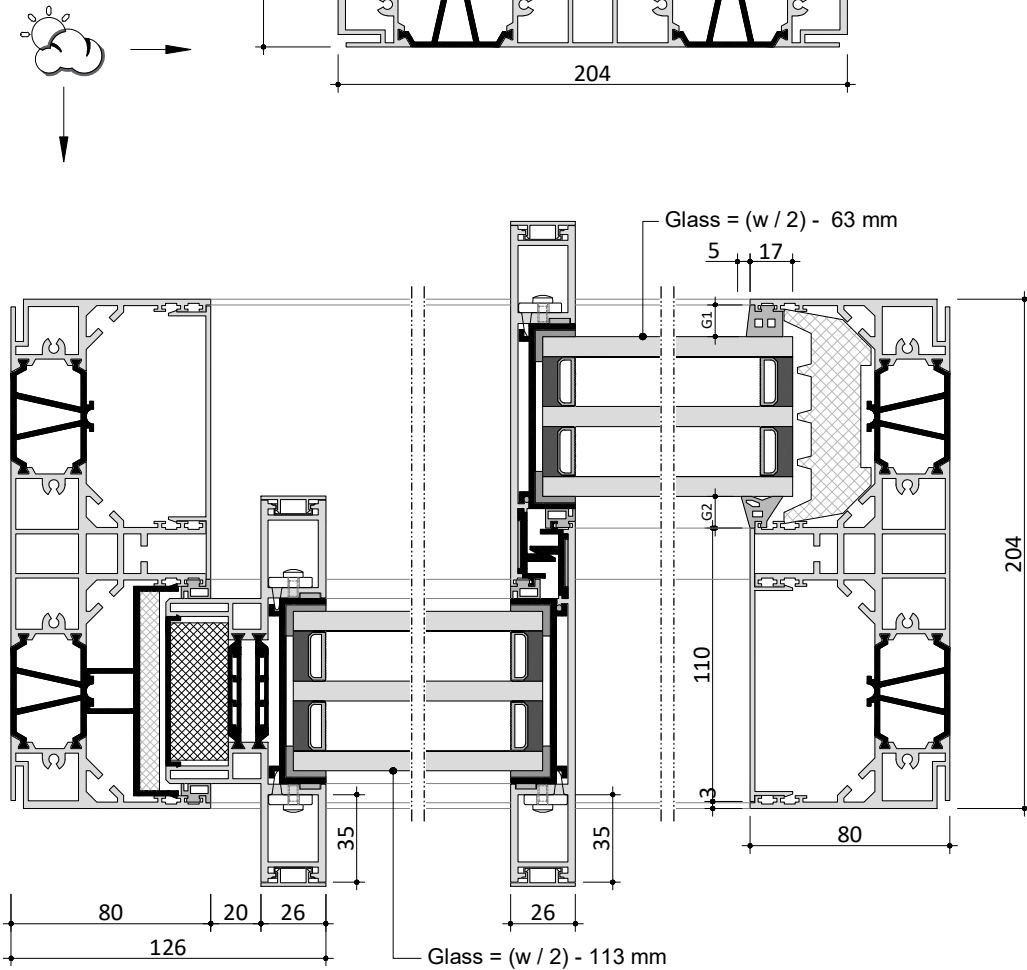
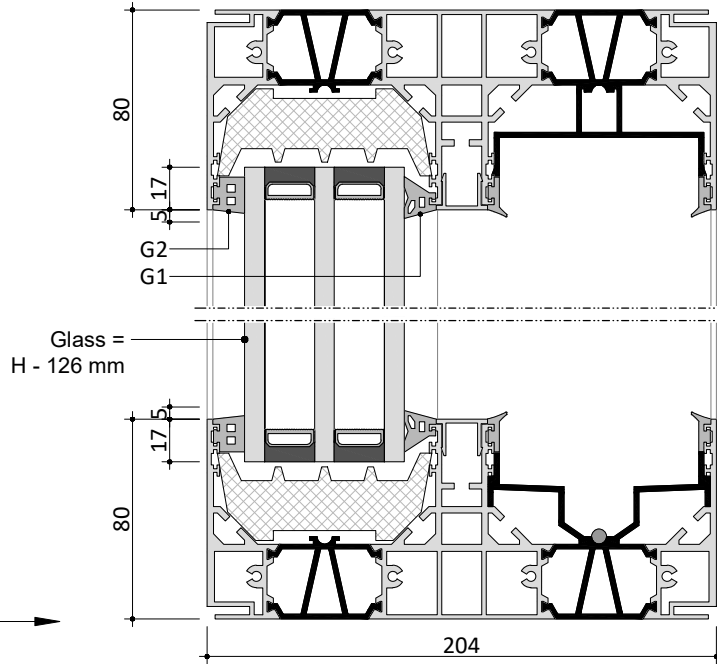



# Technical sections

02-b3

M 1:3

view - sliding with hidden handle

